

# WALL-MOUNTED WORKBENCH INSTALLATION INSTRUCTIONS

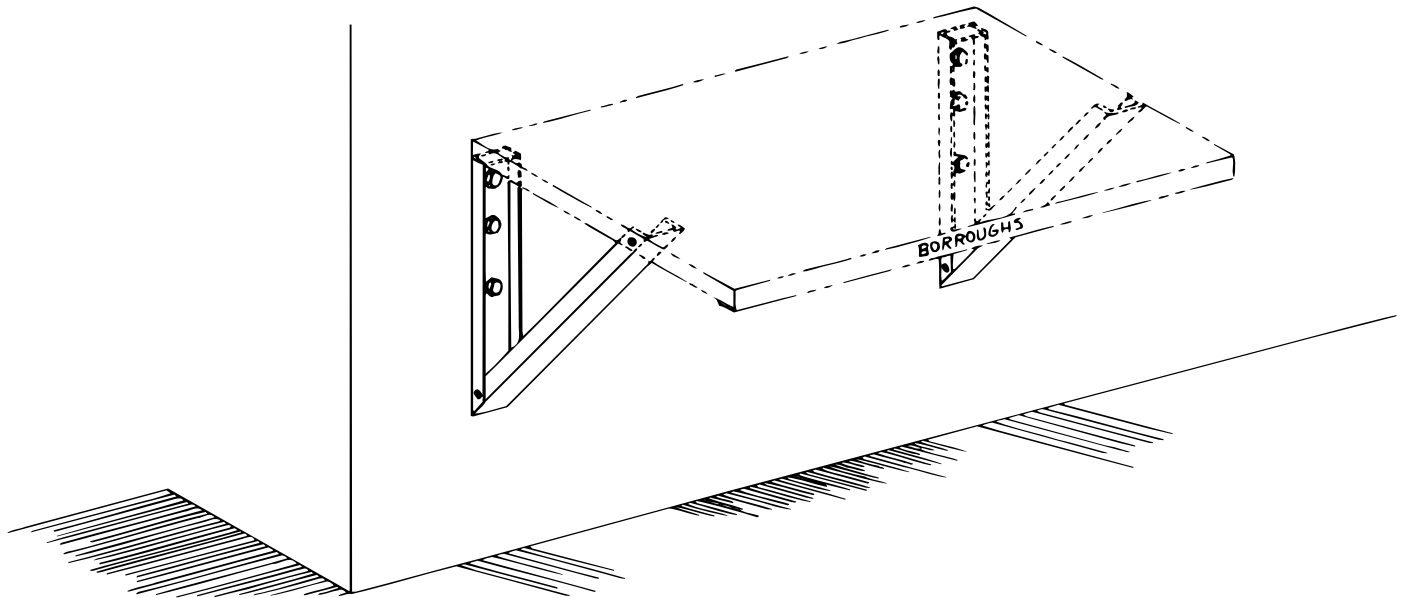

## INSTALLATION SEQUENCE

1. Bolt bottom of diagonal and vertical wall supports together using (2) 1/4-20 x 5/8 Phillips PHMS and nuts.
2. Position wall support assembly at desired height as shown in Figure 1 using desired worksurface height minus 1-3/4". Mark holes using vertical channel as a template. Lag to wall using suitable 3/8-16 fastening device (not included).
3. Position opposite assembly at same height. Align hole centers side-to-side and repeat lagging procedure.

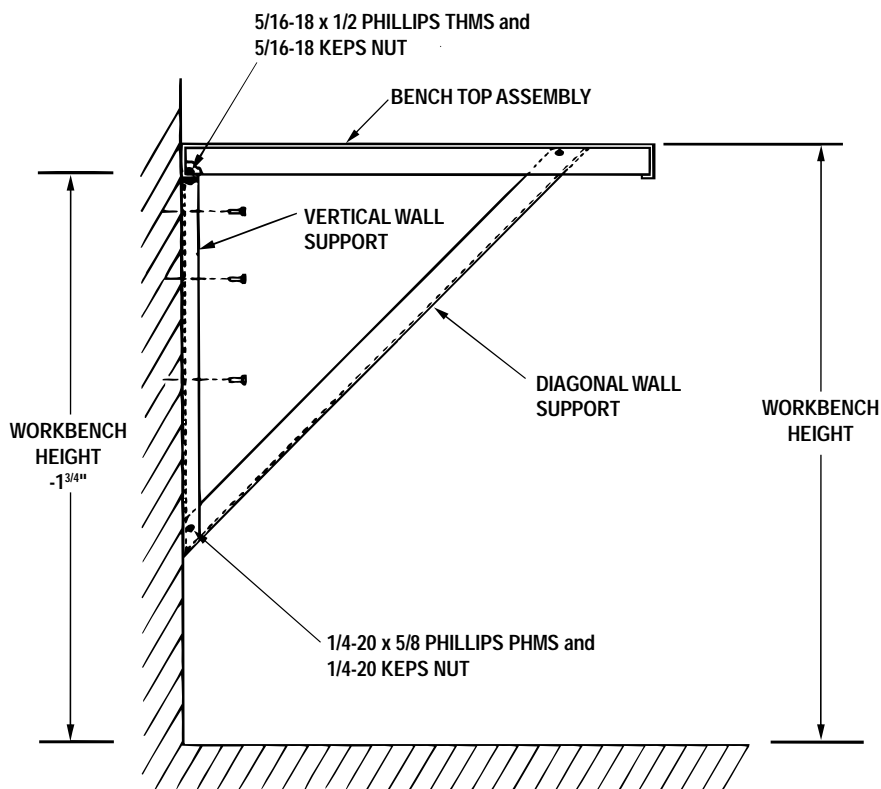

**FIGURE 1**  
(shown in section)

09-50441-00A  
JUNE 1998

**BORROUGHS CORPORATION**  
3002 N. BURDICK STREET • KALAMAZOO, MI 49004-3483  
800-748-0227 • FAX: 616-342-4161 • CANADA: 800-968-0162  
VISIT OUR WEB SITE AT: <http://www.borroughs.com>