

# WILSONSTAK® CANTILEVER SHELVING DETAIL SHEETS

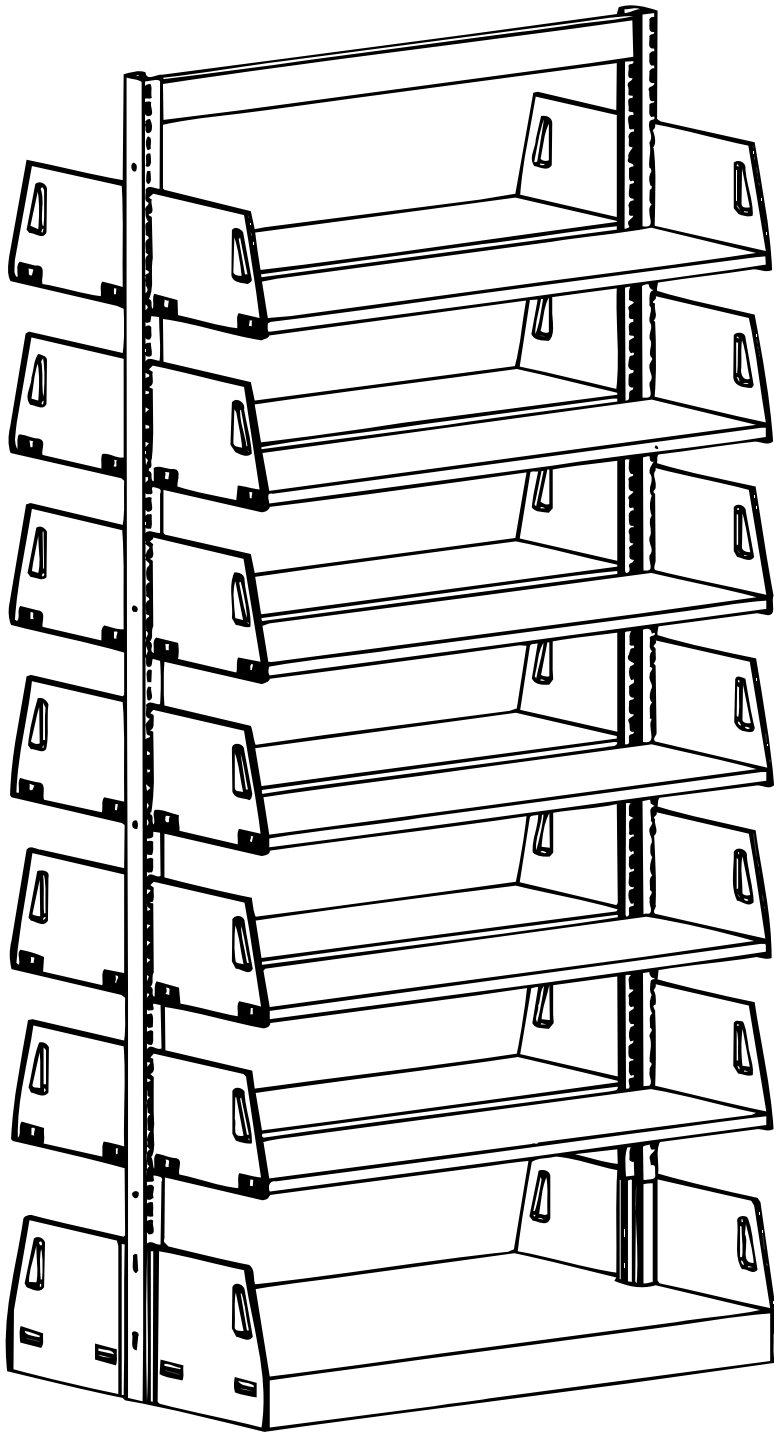

# INDEX

(in alphabetical order)

Backs, Closed .....	49	Shelves -	Adjustable .....	21
Backstop, Adjustable Shelf .....	39		Adjustable, Divider .....	22
Book Supports -			Book Display Unit .....	28
Findable, Hook-on, Wire .....	37		Base, Closed .....	9
Sliding .....	38		Base, Divider .....	10
Bracket Information .....	8		Base, Integral Back .....	12
Canopy Tops .....	42		Base, Multi-Media Browsing Box .....	32
Counter Tops .....	43		Base, Sloping .....	11
Dividers .....	38		Base, Sloping Integral Back .....	13
End Panels (Steel) -			Cassette .....	29
Closed Base .....	40		Cassette/Microfilm .....	29
T-Bar .....	41		Compact Low Profile Browsing Box .....	33
Fillers -			Consultation .....	34
Corner, Closed Base .....	45		Extension Components .....	24
Corner, T-Bar .....	48		Fixed Periodical .....	27
Intermediate Wall .....	46		Heavy-Duty Storage .....	35
Triangular .....	47		Hinged Periodical .....	25
Finished Shelf End Brackets .....	42		Hinged Periodical w/Plexiglass Covers .....	26
Floor Anchoring .....	15		Media Hanger Rack .....	31
Frames (Welded) -			Media Shelf - Single and Double Tier .....	30
Closed Base .....	3		Multi-Media Browsing Box .....	32
T-Bar Base .....	4		Perforated Base .....	14
Spliced Welded Frames .....	5		Shelf Extension .....	23
Identity Holders - Continuous Card, Range Finder, Shelf Label .....	44		Sliding Reference .....	36
Leg Base, T-Bar .....	18		Storage Shelf .....	35
Leg Base, T-Bar Corner Condition .....	48		Work .....	35
Leg Base Units -			Zig Zag Paperback .....	31
Single Faced .....	19			
Double Faced .....	20		Transverse Tie Struts .....	50
Mobile Book Stack .....	52		Triangular Reinforcing Gussets - Single Face .....	16
Newspaper Rack .....	51		Double Face .....	17
			Wall Hung Column Strip .....	6-7

# WELDED FRAME

## For Closed Base

(shipped from the factory as illustrated)

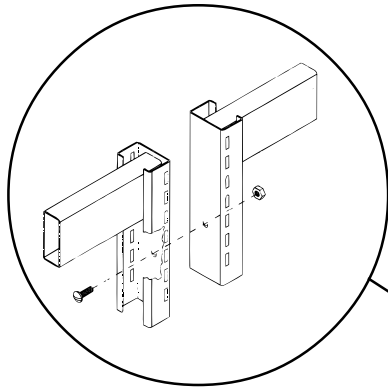

This connection equal to 11 gauge.

Standard Width		
Height	36" Wide Unit No.	30" Wide Unit No.
42"	31231-010	31230-030
54"	31231-020	31230-040
66"	31231-030	31230-050
78"	31231-040	31230-060
84"	31231-050	31230-070
90"	31231-060	31230-080
93"	31231-070	31230-090

Special widths and heights available.

**Levelers:** Frames are supplied with two adjustable levelers and floor glides. Levelers can be easily installed and adjusted.

**Carpet Pins:** Will be provided for frames and base brackets at a slight additional cost. Carpet Pin location at base of upright carries load where it should be when unit is loaded. Because of our unique welded construction there are two carpet pins where uprights are joined together.

**Top Rail:** 16 gauge x 1" x 2-1/2" rectangular tube.

**Bottom Rail:** 16 gauge x 1" x 1-3/4" formed channel, welded with formations upward.

**Slotted Upright:** At least 16 gauge x 1-1/4" x 2" formed "C" channel.

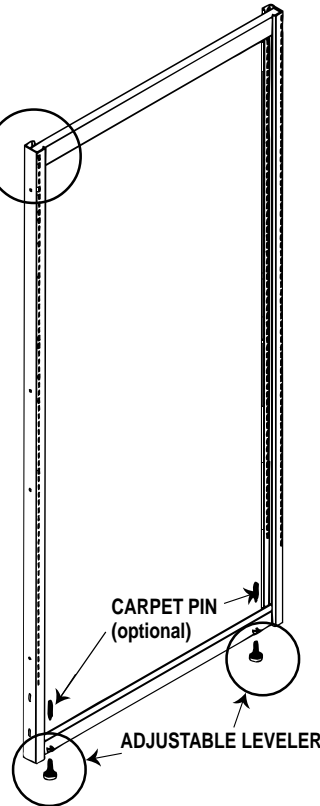

### SINGLE FACE

### DOUBLE FACE

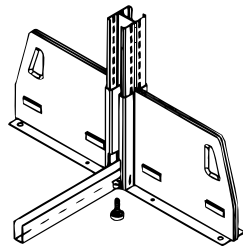
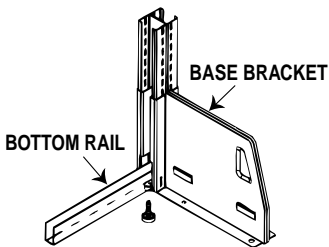

Adjustable Leveler (standard)  
Carpet Pin (must be specified)

### ADJUSTABLE LEVELER INSTALLATION

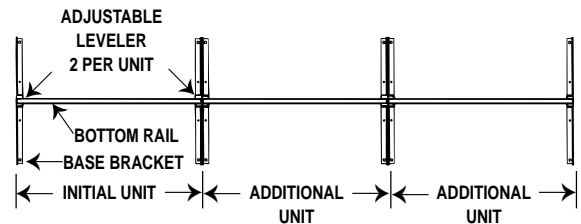

### CARPET PIN INSTALLATION

(extra cost - must be specified)

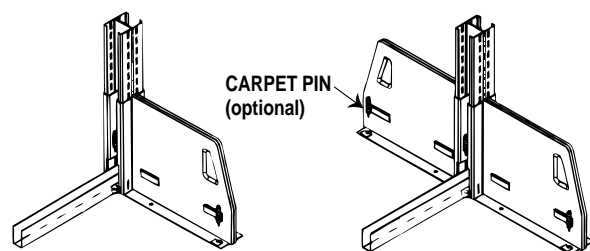
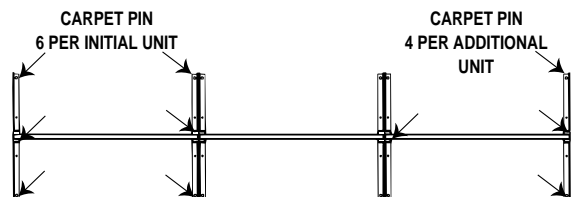

# T-BAR WELDED FRAME

For T-Bar Leg Base

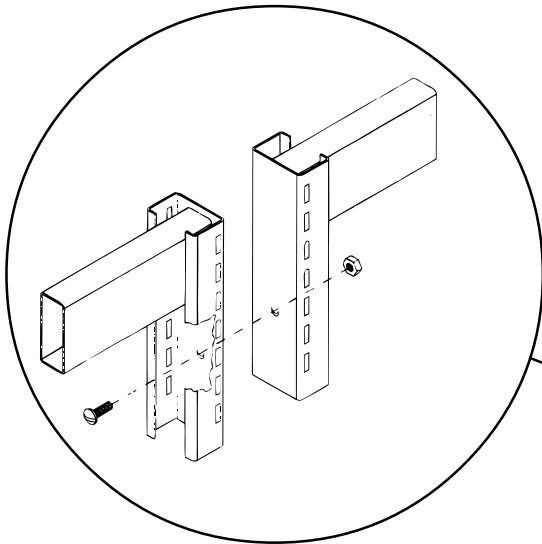

This connection equal to 11 gauge.

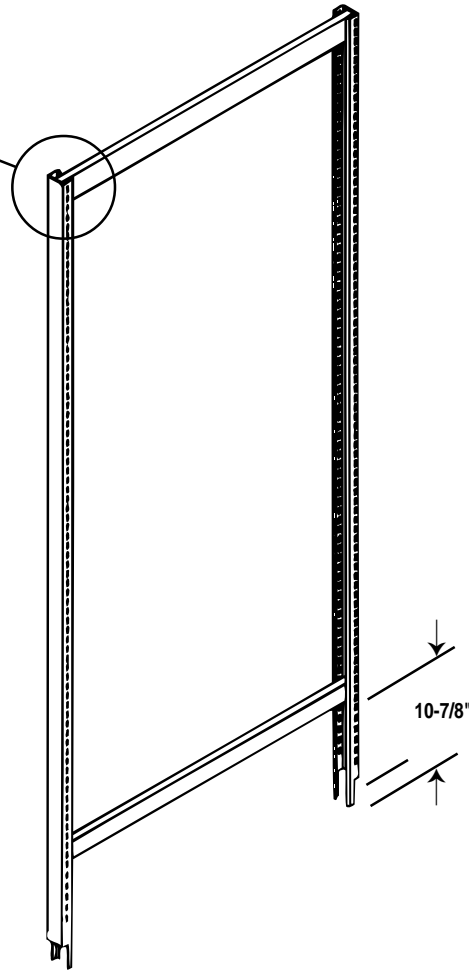

## Standard Width

Height	36" Wide Unit No.
42"	31235-070
66"	31235-090
78"	31236-000
84"	31236-010
90"	31236-020
93"	31236-030

**Top Rail:** 16 gauge x 1" x 2-1/2" rectangular tube.

**Bottom Rail:** 16 gauge x 1" x 1-3/4" formed channel.

**Uprights:** At least 16 gauge x 1-1/4" x 2" formed "C" channel.

# SPLICED WELDED FRAMES

Used when height of frame exceeds 120".

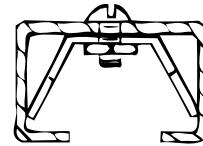
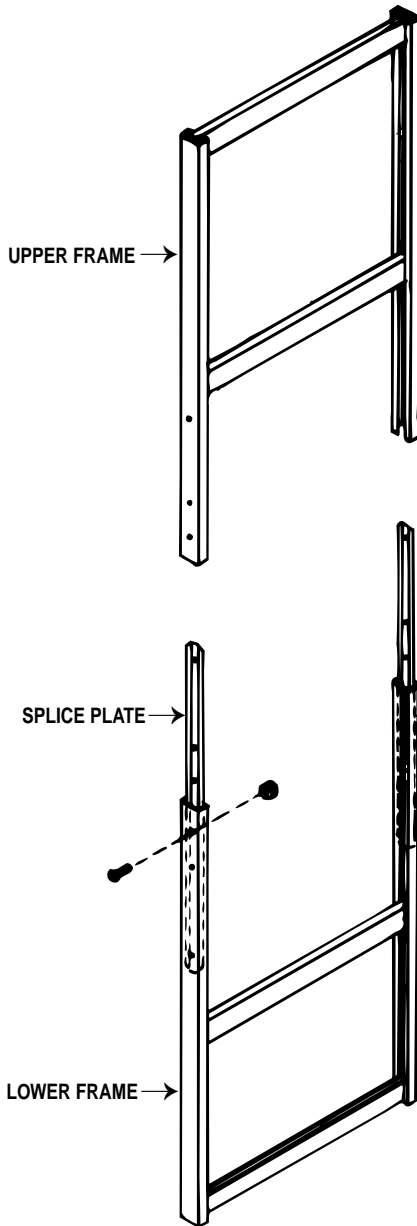

**SPLICE  
SECTION VIEW**

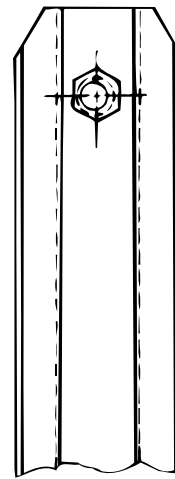

**SPLICE PLATE DETAIL**

Lower frames are furnished with splice plates welded in place.  
Upper frame bolts on for easy installation.

# WALL HUNG COLUMN STRIP

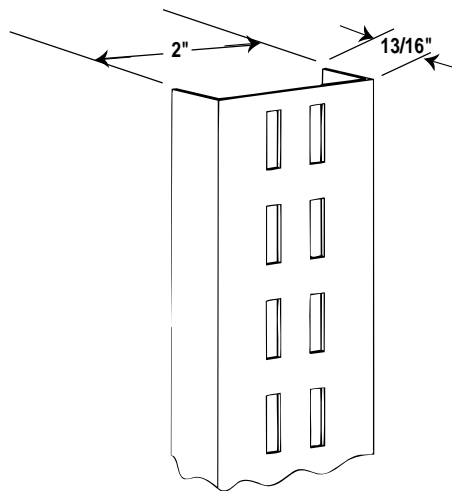
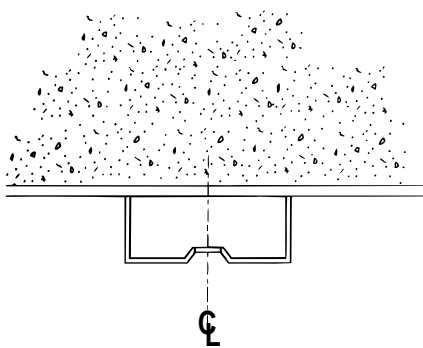
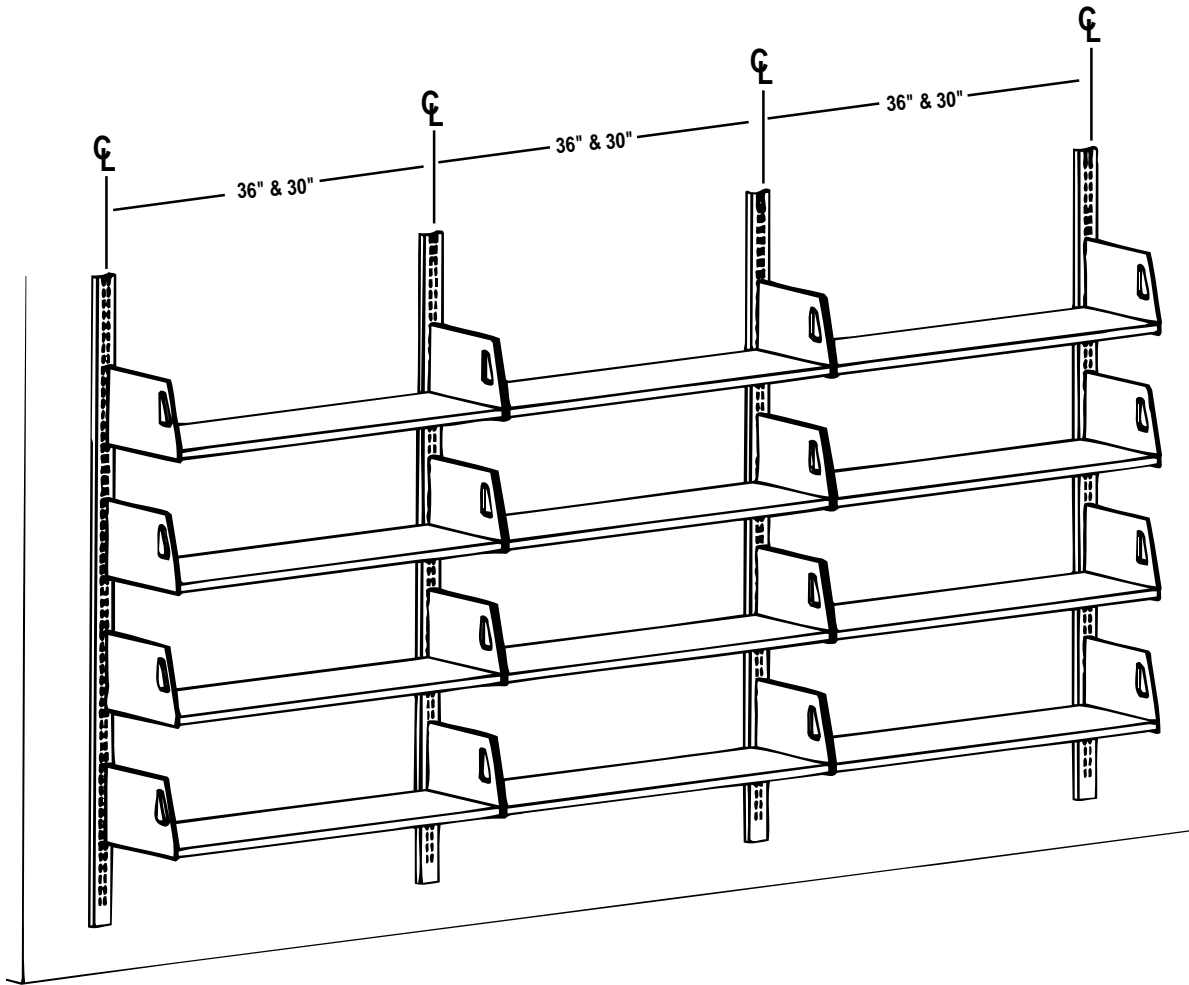

Height	Unit No.
42"	31280-010
54"	31280-020
66"	31280-030
78"	31280-040
84"	31280-050
90"	31280-060

**Material:** 16 gauge, Channel shaped.  
**Standard Heights:** 42", 54", 66", 78", 84" 90"  
 Special heights available.

# WALL HUNG COLUMN STRIP

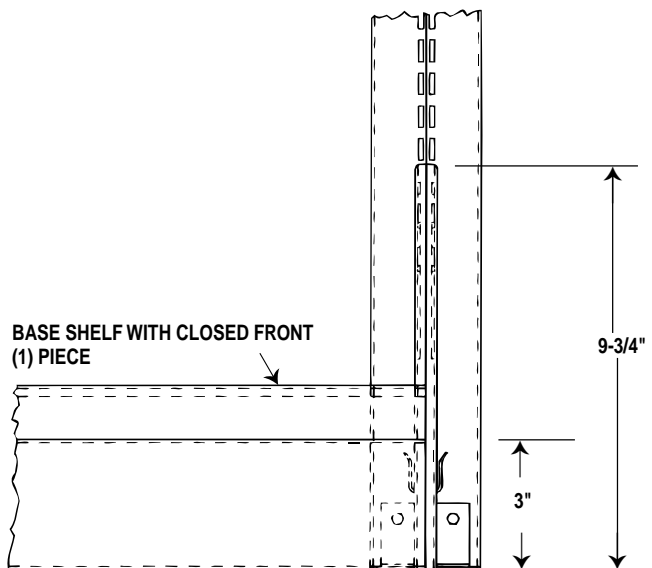
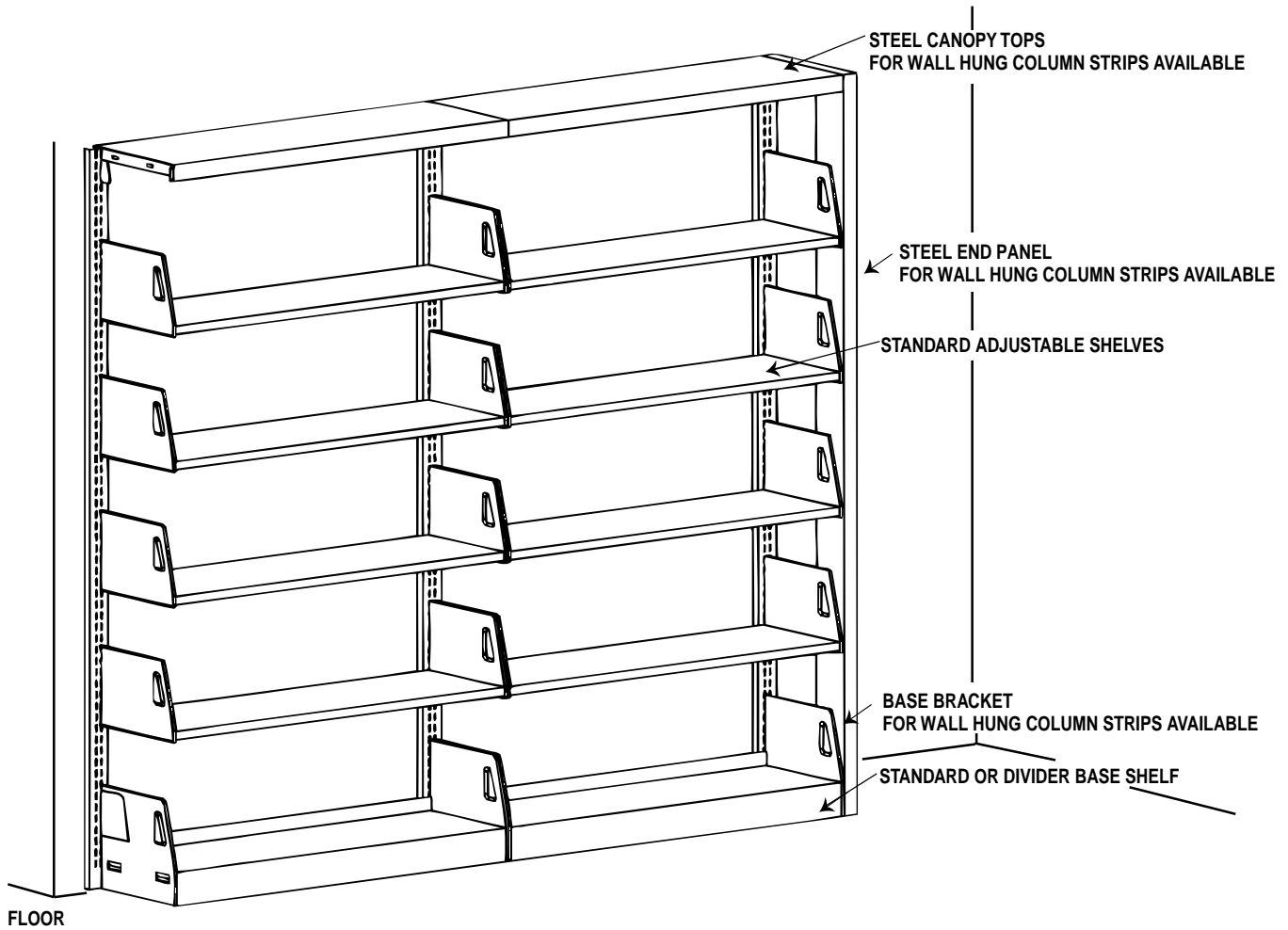

**BASE BRACKET DETAIL**

Contact factory for information on wall hung column strip accessories

# BRACKET INFORMATION

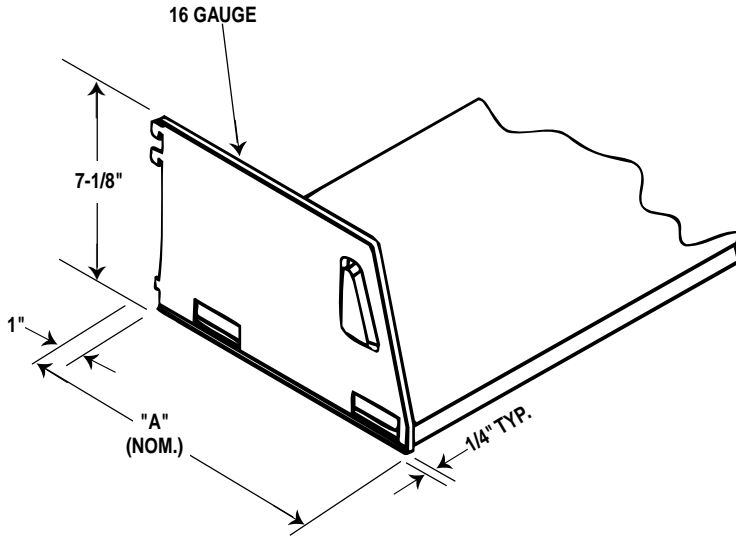

## ADJUSTABLE SHELF END BRACKETS

Brackets are formed of 16 gauge steel. Brackets are left handed (LH) and right handed (RH). One pair of brackets is furnished with each shelf.

Note: LH shown

Actual depth of shelf is 1" less than nominal.

Nominal  
Depth

"A"
8"
9"
10"
12"
14"
16"

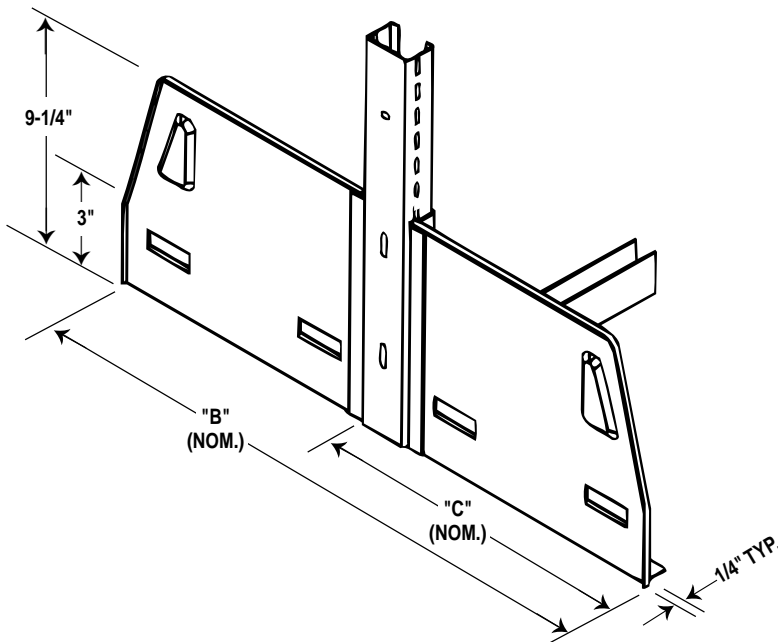

## BASE BRACKET

Base brackets are formed of 16 gauge steel. Brackets are available in double face ("B") and single faced ("C") configurations. Single face base brackets are left handed (LH) and right handed (RH). One pair of brackets is furnished with each shelf.

Note: LH shown.

Base brackets actual overall dimensions:

Single Face: Nominal + 1-3/8"

Double Face: Nominal + 7/16"

Nominal Depths

"B"	"C"
16"	8"
18"	9"
20"	10"
24"	12"
32"	16"

# CLOSED BASE SHELVES

Flat Surface

Brackets 16 Gauge • Shelves 18 Gauge

**SINGLE FACED**

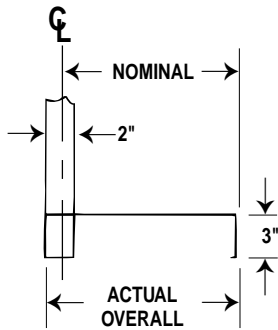
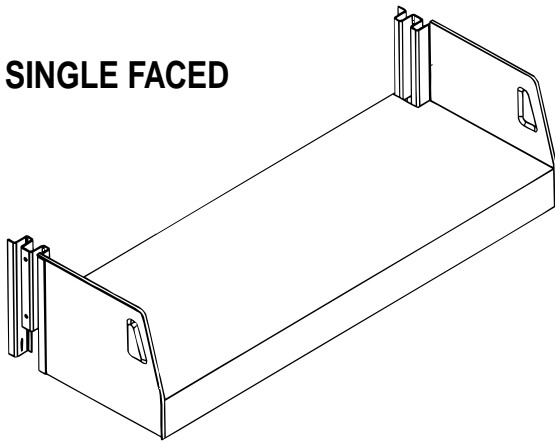

Standard Widths

Nominal Depth	36" Wide Unit No.	30" Wide Unit No.
8"	MBS608	MBS008
9"	MBS609	MBS009
10"	MBS610	MBS010
12"	MBS612	MBS012
16"	MBS616SF	MBS016SF

**DOUBLE FACED**

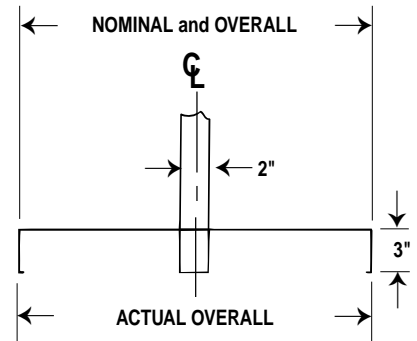
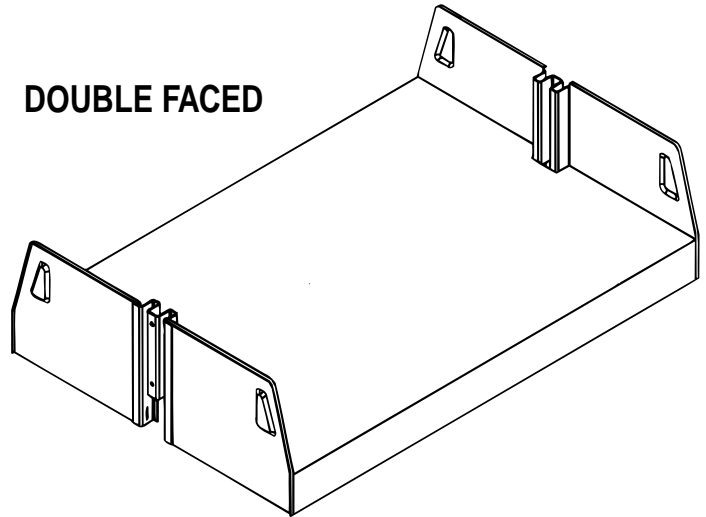

Standard Widths

Nominal Depth	36" Wide Unit No.	30" Wide Unit No.
16"	MBS616	MBS016
18"	MBS618	MBS018
20"	MBS620	MBS020
24"	MBS624	MBS024
32"	MBS632	MBS032

**SINGLE FACE**

Actual Overall Depth: Nominal + 1-3/8"

**DOUBLE FACE**

Actual Overall Depth: Nominal + 7/16"

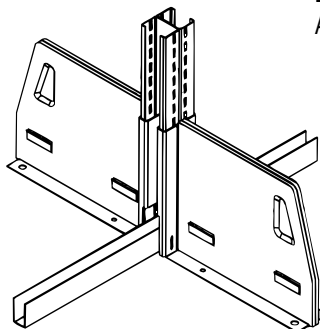

This connection when properly bolted is equal to 11 gauge.

# DIVIDER BASE SHELVES

Divider Type  
 Brackets 16 Gauge • Shelves 18 Gauge  
 Dividers 18 Gauge 6" or 10" High

## SINGLE FACED

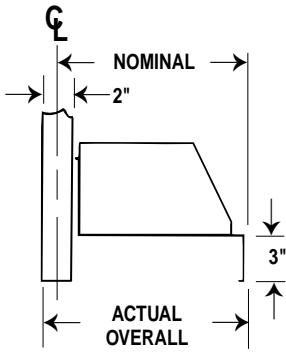
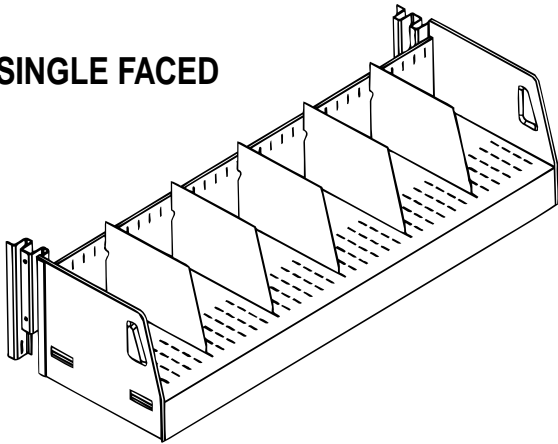

Standard Widths

Nominal Depth	36" Wide Unit No.	30" Wide Unit No.
10"	MDBS610	MDBS010
12"	MDBS612	MDBS012
13"	MDBS613	MDBS013
16"	MDBS616	MDBS016

## DOUBLE FACED

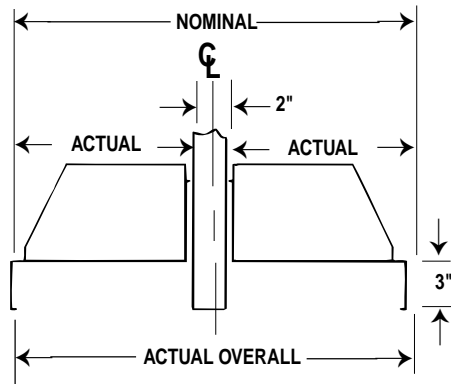
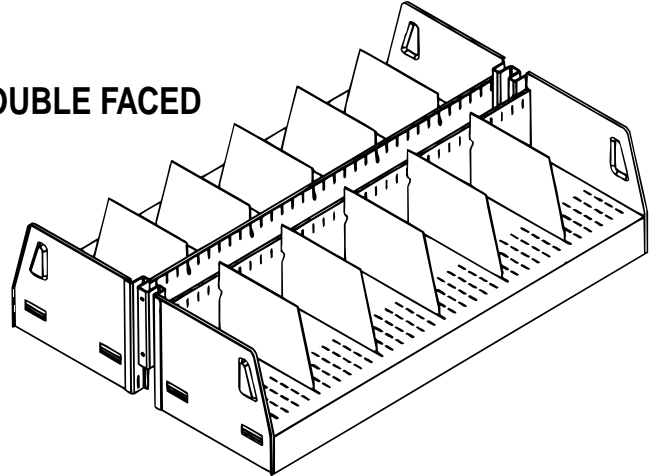

Standard Widths

Nominal Depth	36" Wide Unit No.	30" Wide Unit No.
20"	MDBS620	MDBS020
24"	MDBS624	MDBS024
26"	MDBS626	MDBS026
32"	MDBS632	MDBS032

### SINGLE FACE

Actual Overall Depth: Nominal + 1-3/8"

Five 6" high dividers are included in the 36" width.  
 Four 6" high dividers are included in the 30" width.  
 Shelf is slotted on 1" centers.

### DOUBLE FACE

Actual Overall Depth: Nominal + 7/16"

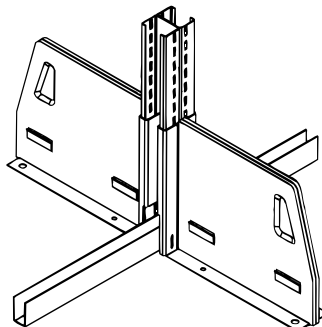

This connection when properly bolted is equal to 11 gauge.

# SLOPING BASE SHELVES

Brackets 16 Gauge • Shelves 18 Gauge

## SINGLE FACED

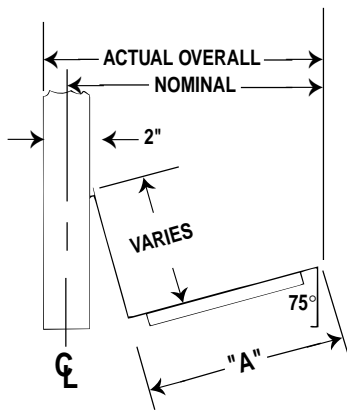
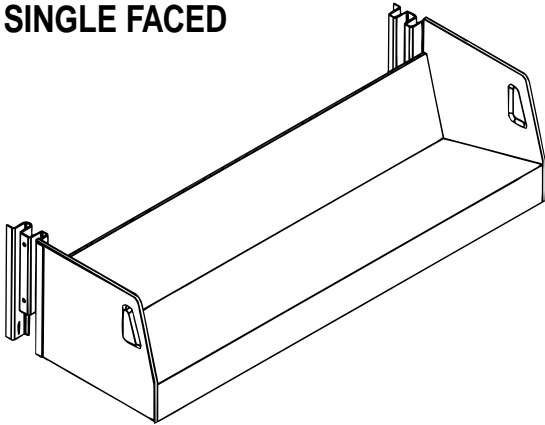

Standard Widths

Nominal Depth	"A" Dim.	36" Wide Unit No.	30" Wide Unit No.
8"	5-1/2"	MBS608SLP	MBS008SLP
9"	6-1/2"	MBS609SLP	MBS009SLP
10"	7-1/2"	MBS610SLP	MBS010SLP
12"	9-1/2"	MBS612SLP	MBS012SLP

## DOUBLE FACED

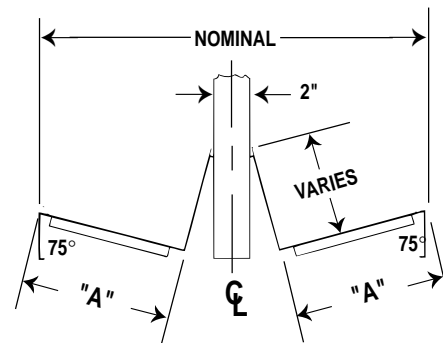
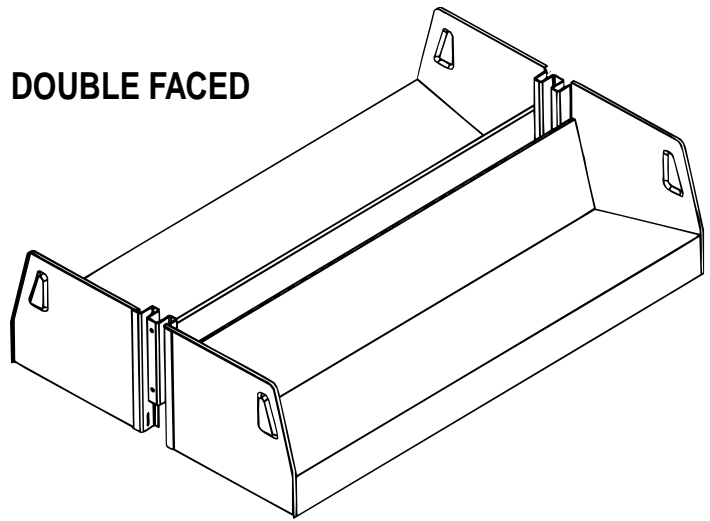

Standard Widths

Nominal Depth	A Dim.	36" Wide Unit No.	30" Wide Unit No.
18"	5-1/2"	MBS616SLP	MBS016SLP
18"	6-1/2"	MBS618SLP	MBS018SLP
20"	7-1/2"	MBS620SLP	MBS020SLP
24"	9-1/2"	MBS624SLP	MBS024SLP

### SINGLE FACE

Actual Overall Depth: Nominal + 1-3/8"

### DOUBLE FACE

Actual Overall Depth: Nominal + 7/16"

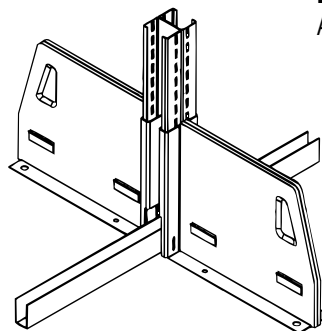

This connection when properly bolted is equal to 11 gauge.

# INTEGRAL BACK BASE SHELVES

Brackets 16 Gauge • Shelves 18 Gauge

## SINGLE FACED

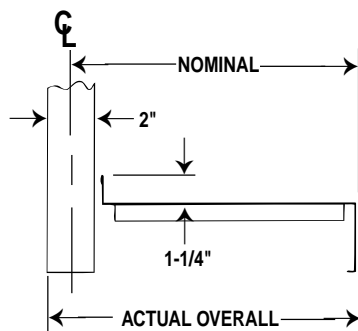
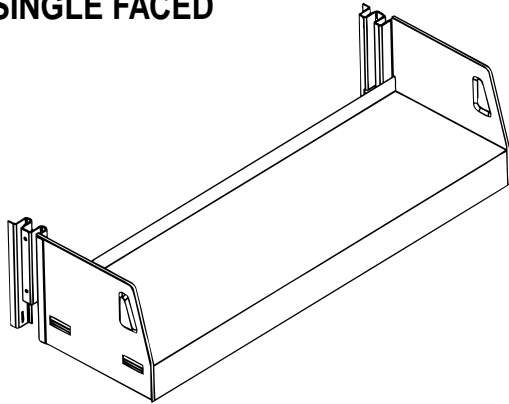

Standard Widths

Nominal Depth	36" Wide Unit No.	30" Wide Unit No.
8"	MIBS608	MIBS008
9"	MIBS609	MIBS009
10"	MIBS610	MIBS010
12"	MIBS612	MIBS012

## DOUBLE FACED

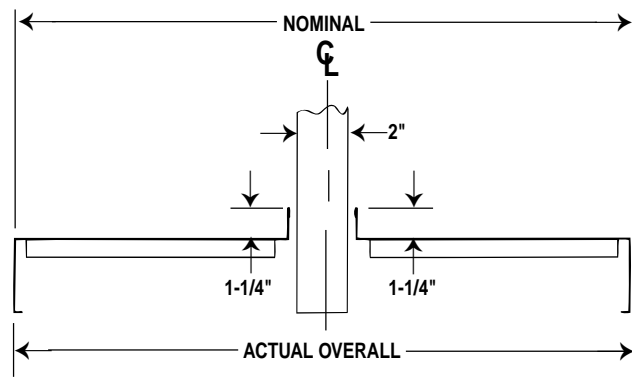
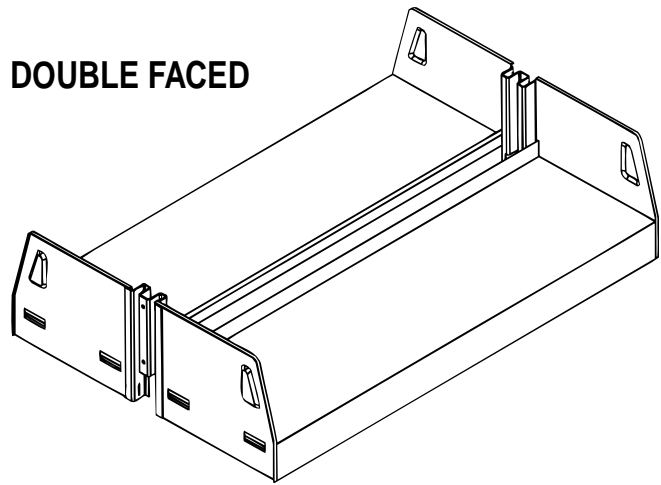

Standard Widths

Nominal Depth	36" Wide Unit No.	30" Wide Unit No.
16"	MIBS616	MIBS016
18"	MIBS618	MIBS018
20"	MIBS620	MIBS020
24"	MIBS624	MIBS024

## SINGLE FACE

Actual Overall Depth: Nominal + 1-3/8"

## DOUBLE FACE

Actual Overall Depth: Nominal + 7/16"

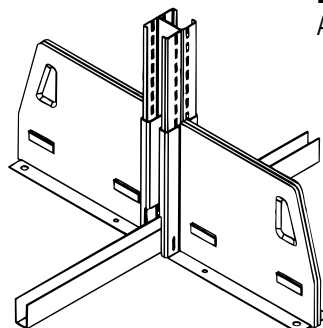

This connection when properly bolted is equal to 11 gauge.

# SLOPING INTEGRAL BACK BASE SHELVES

Brackets 16 Gauge • Shelves 18 Gauge

## SINGLE FACED

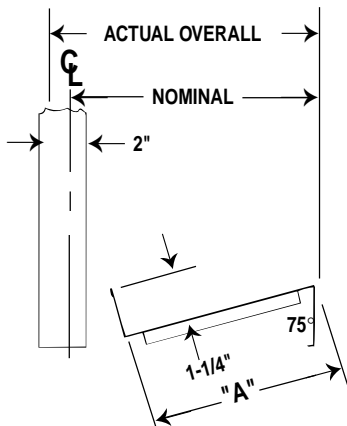
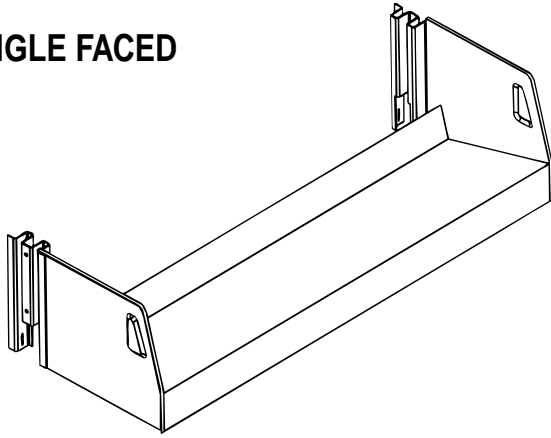

Standard Widths

Nominal Depth	"A" Dim.	36" Wide Unit No.	30" Wide Unit No.
8"	6-17/32"	MSIBS608	MSIBS008
9"	7-17/32"	MSIBS609	MSIBS009
10"	8-17/32"	MSIBS610	MSIBS010
12"	10-17/32"	MSIBS612	MSIBS012

## DOUBLE FACED

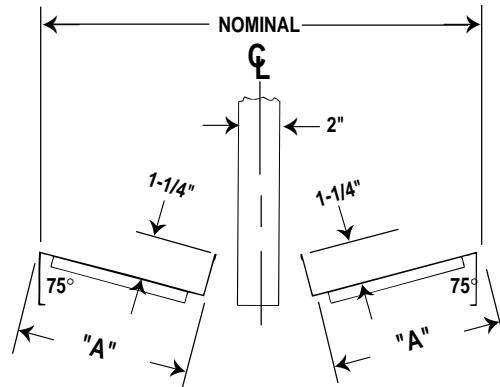
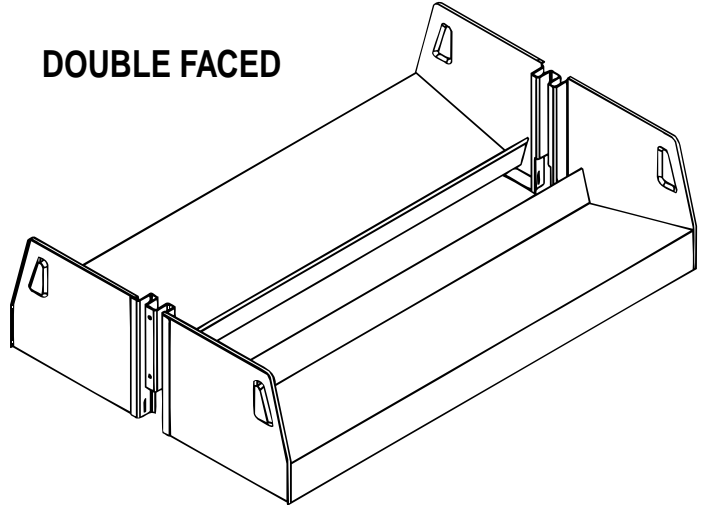

Standard Widths

Nominal Depth	"A" Dim.	36" Wide Unit No.	30" Wide Unit No.
18"	6-17/32"	MSIBS616	MSIBS016
18"	6-17/32"	MSIBS618	MSIBS018
20"	6-17/32"	MSIBS620	MSIBS020
24"	6-17/32"	MSIBS624	MSIBS024

### SINGLE FACE

Actual Overall Depth: Nominal + 1-3/8"

### DOUBLE FACE

Actual Overall Depth: Nominal + 7/16"

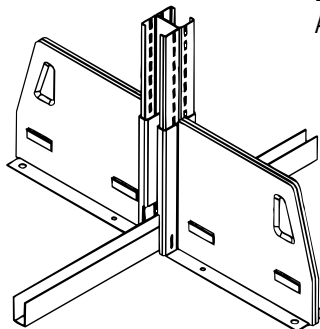

This connection when properly bolted is equal to 11 gauge.

# PERFORATED BASE SHELF

Used where a standard base shelf would restrict air flow from heating or air conditioner registers.

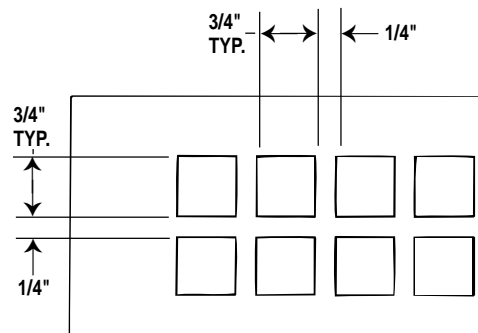
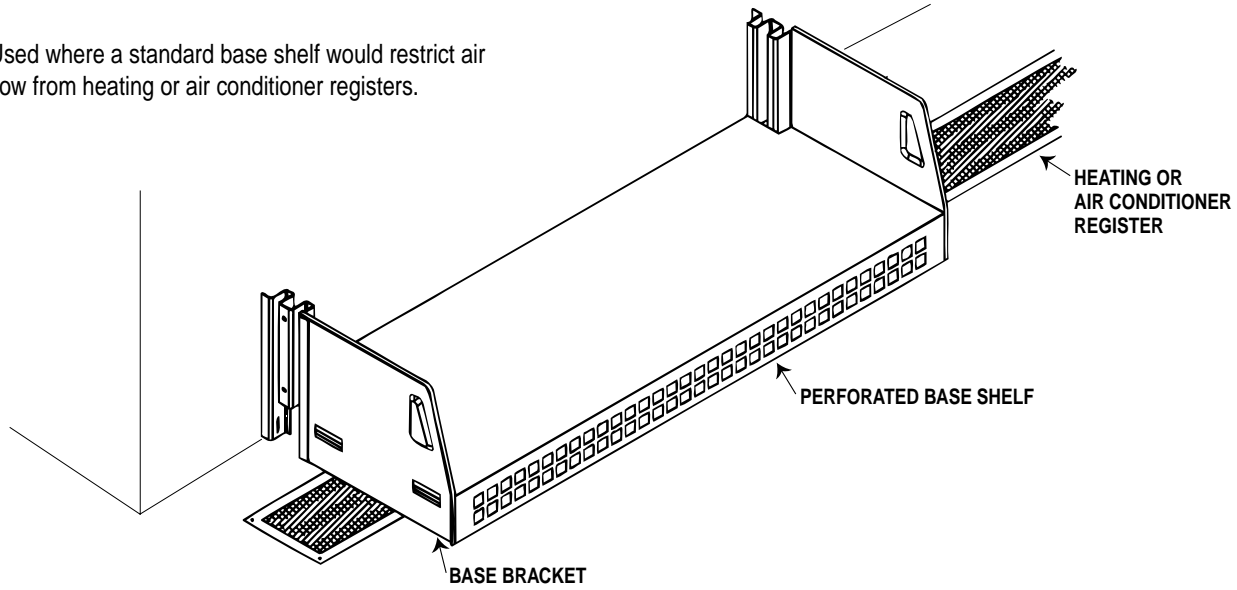

PERFORATION DETAIL

# FLOOR ANCHORING

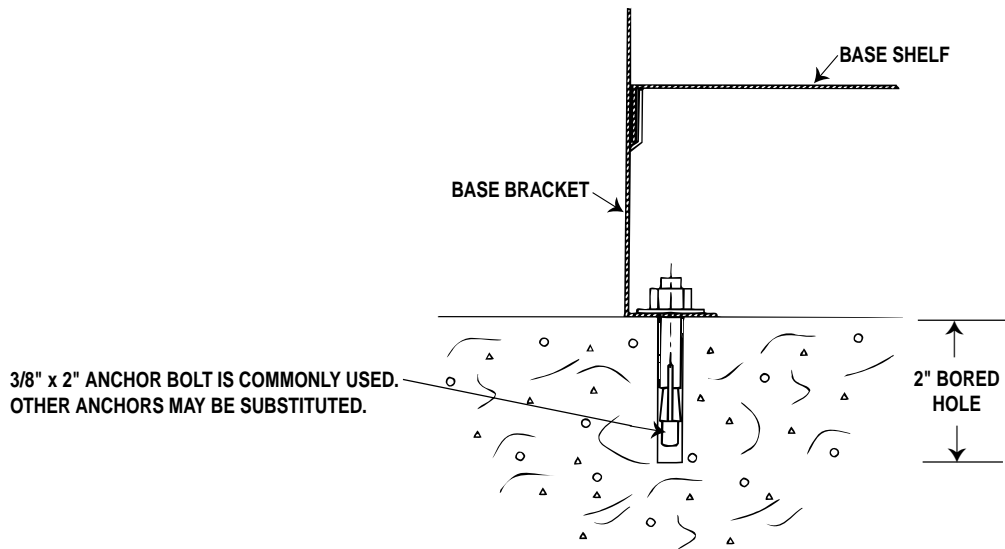
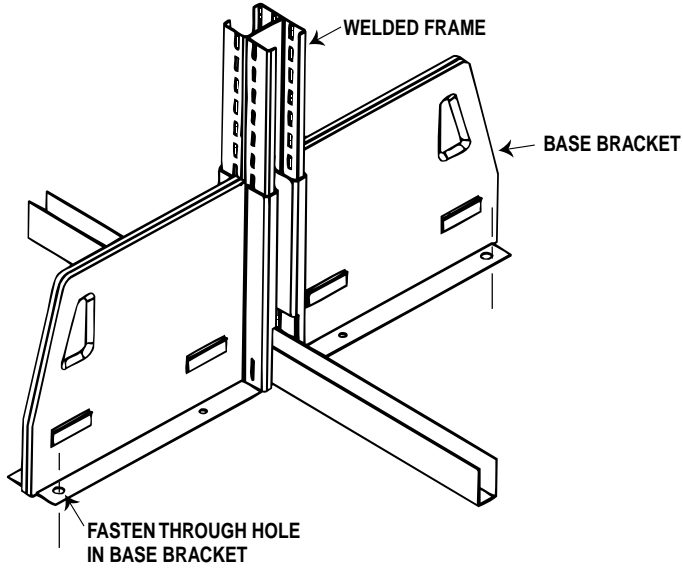

**ANCHORING DETAIL**

Contact factory for technical support on anchor locations, floor conditions and applications.

# SINGLE FACED TRIANGULAR REINFORCING GUSSETS

Used on all mobile installations to increase stability of range. Can also be used on freestanding ranges for increased strength or for seismic applications.

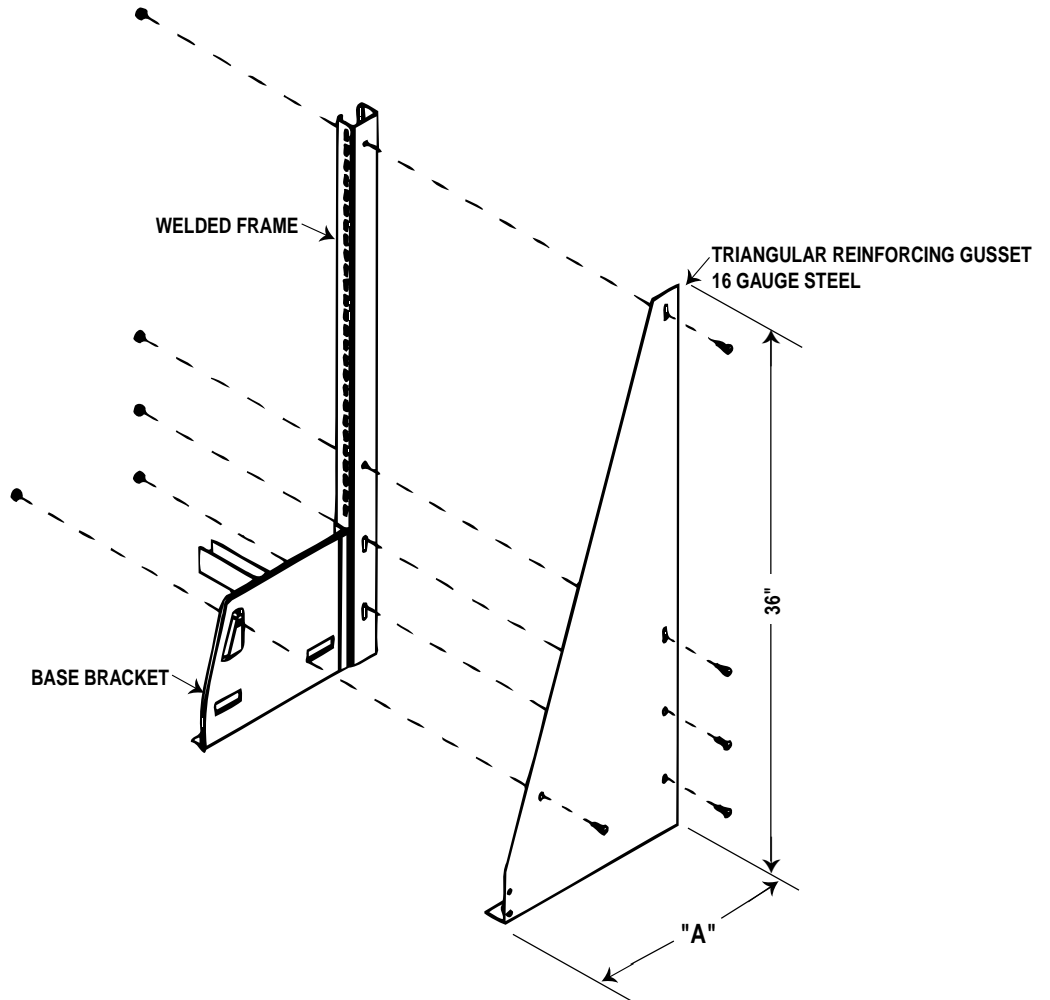

Standard Widths

Nominal Depth	"A" Dim.	LH Unit No.	RH Unit No.
8"	9-3/16"	31210-005	31210-006
9"	10-3/16"	31210-010	31210-011
10"	11-3/16"	31210-020	31210-021
12"	13-3/16"	31210-025	31210-026

# DOUBLE FACED TRIANGULAR REINFORCING GUSSETS

Used on all mobile installations to increase stability of range. Can also be used on freestanding ranges for increased strength or for seismic applications.

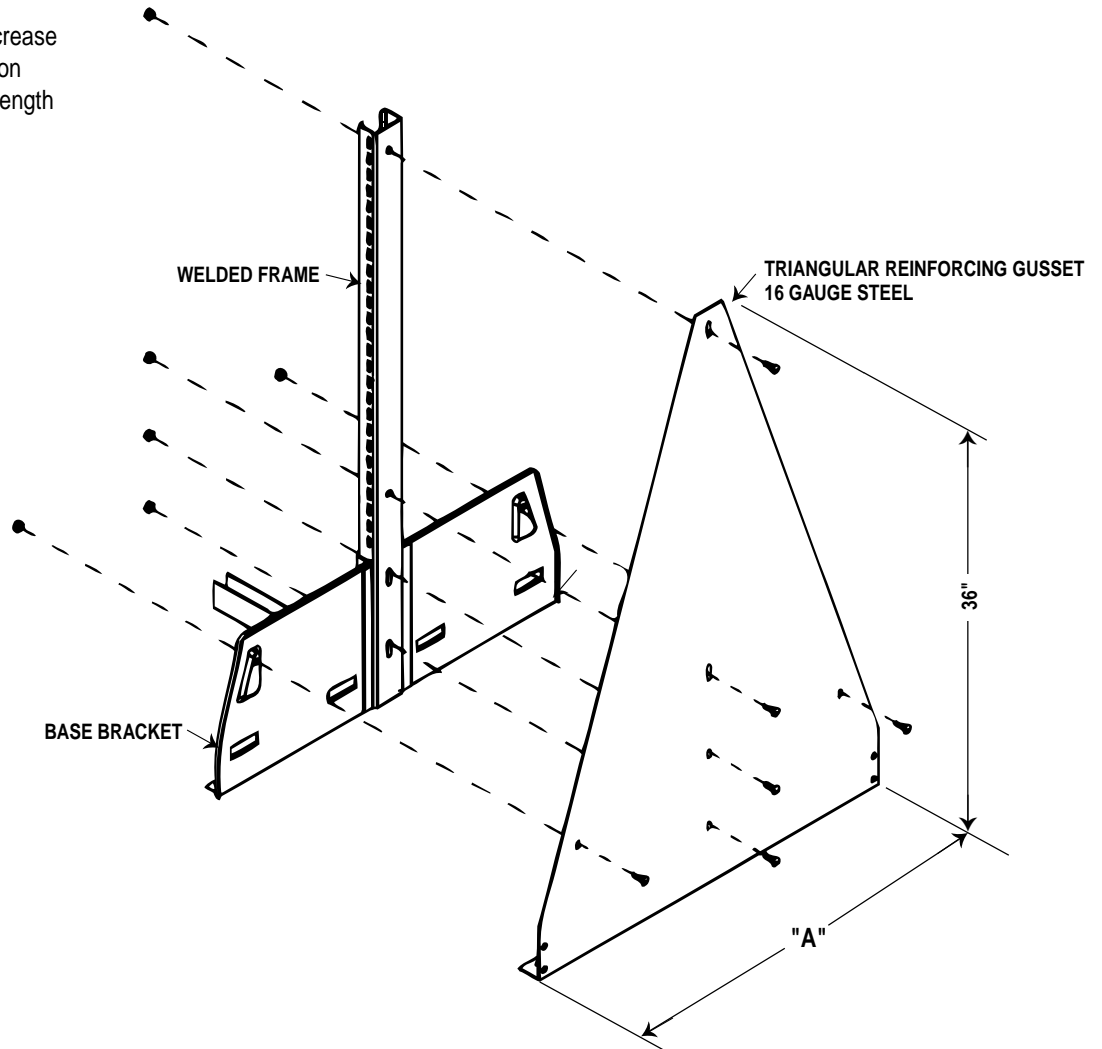

Standard Widths

Nominal Depth	"A" Dim.	Unit No.
16"	16-3/8"	31210-040
18"	18-3/8"	31210-060
20"	20-3/8"	31210-070
24"	24-3/8"	31210-090
32"	32-3/8"	31210-095

# T-BAR LEG BASE

"A" Dim.	Unit No.
21-1/2"	MTBDF21
25-1/2"	MTBDF25

Double face T-bar leg bases also available with casters for mobile units. See Page 52. Contact factory for recommended applications.

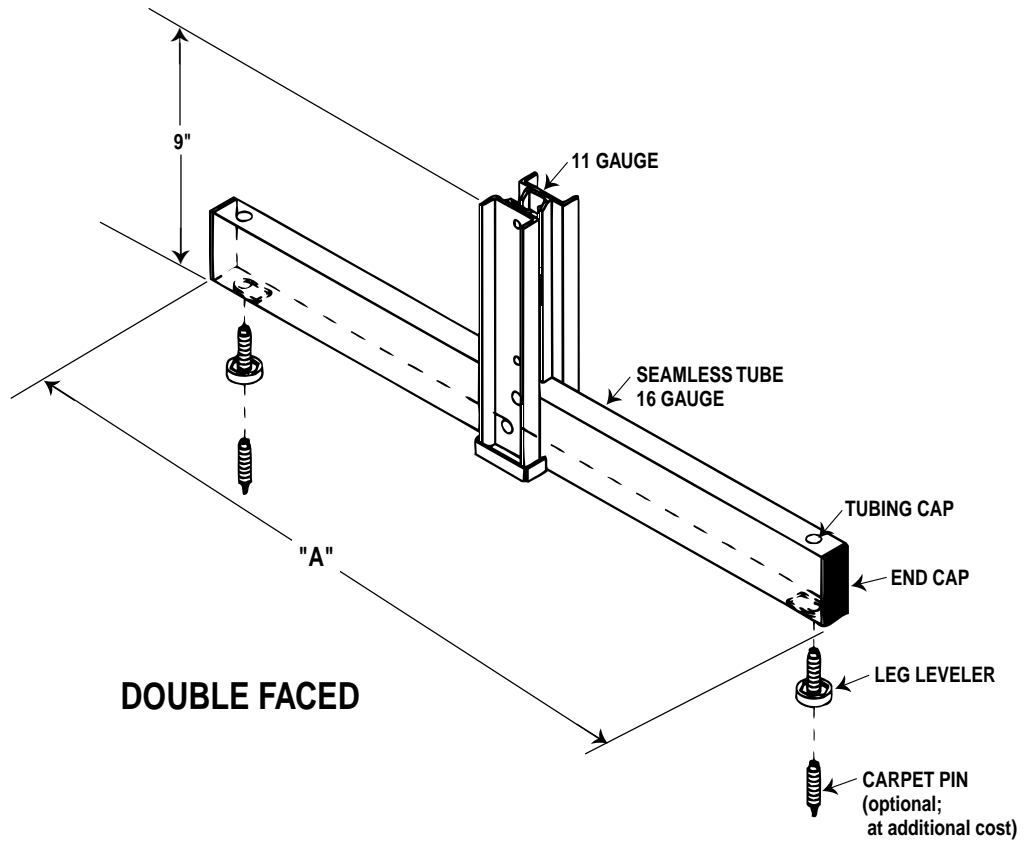

Depth	Unit No.
13-3/4"	MTBSF13

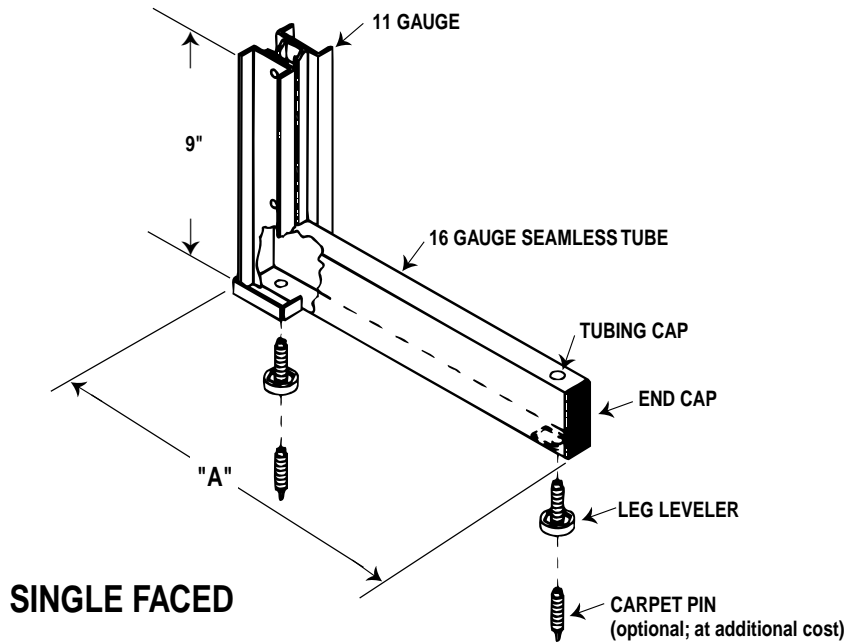

# SINGLE FACED T-BAR LEG BASE RANGE

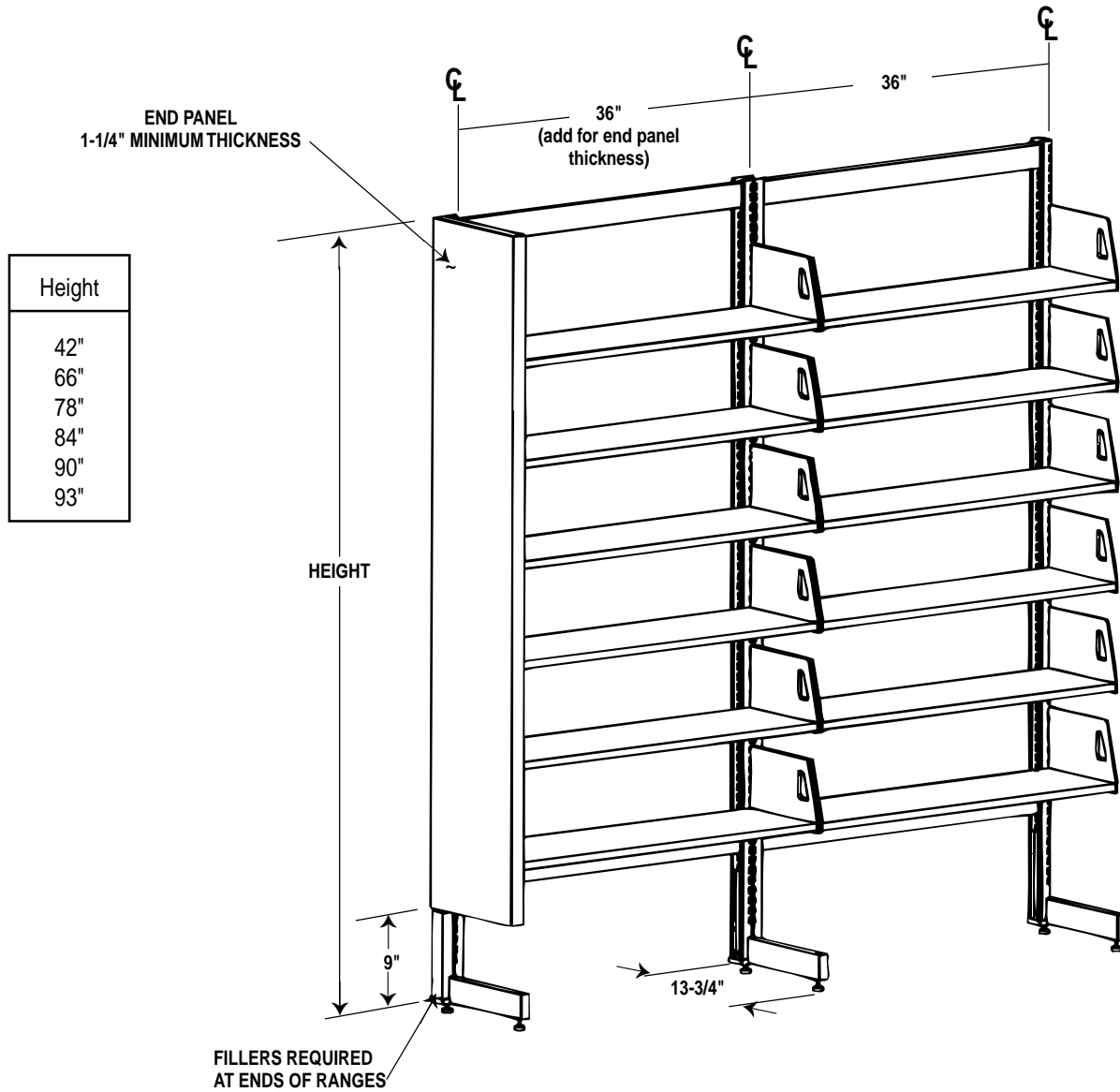

# DOUBLE FACED T-BAR LEG BASE RANGE

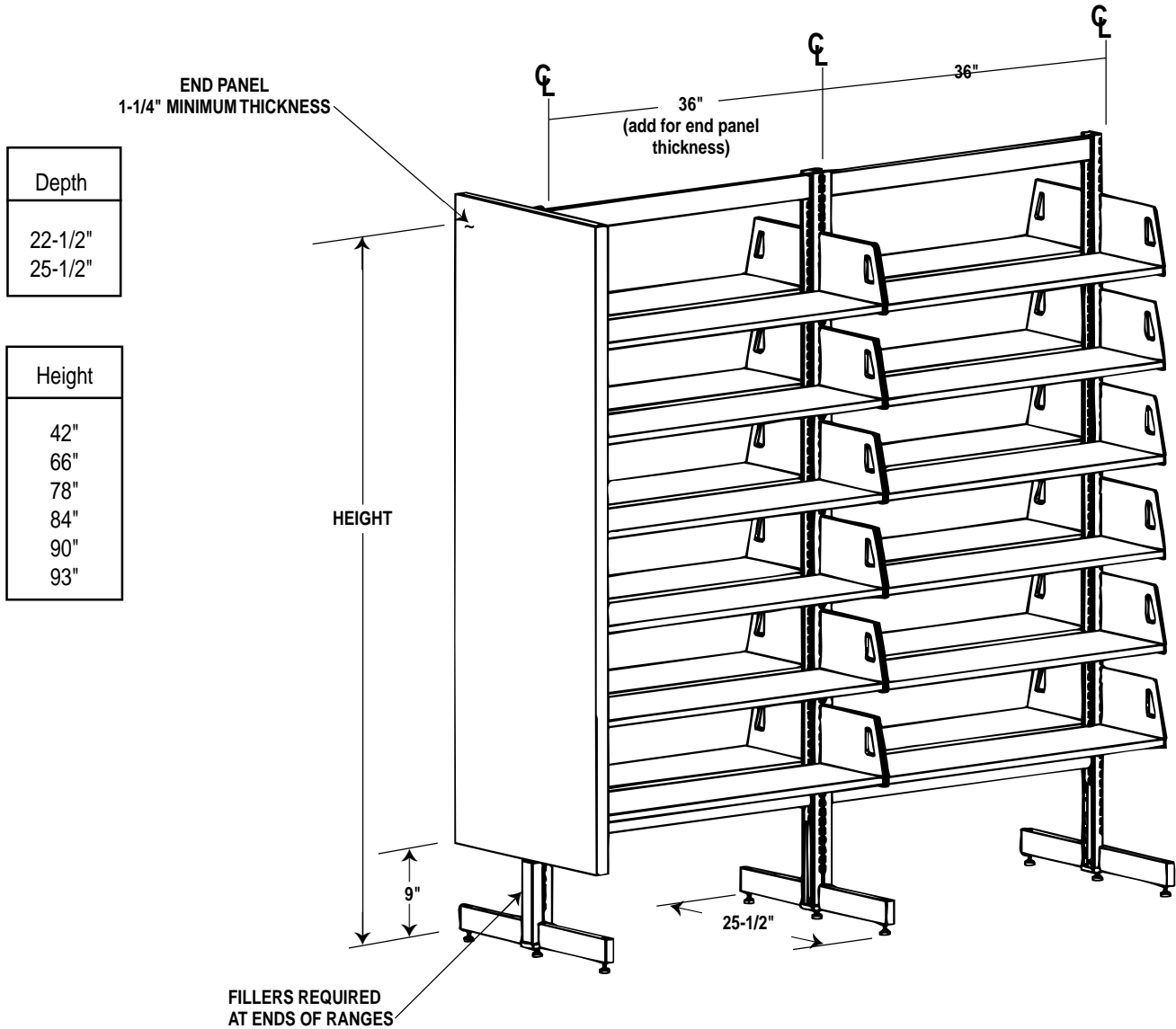

# ADJUSTABLE SHELVES

Brackets 16 Gauge • Shelves 18 Gauge

Standard Widths: 36" & 30"

Special Widths Available

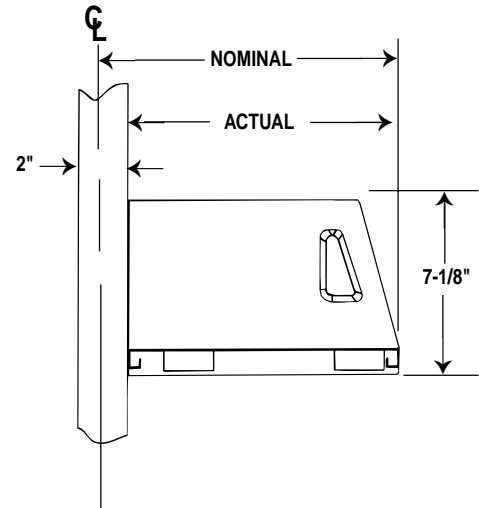
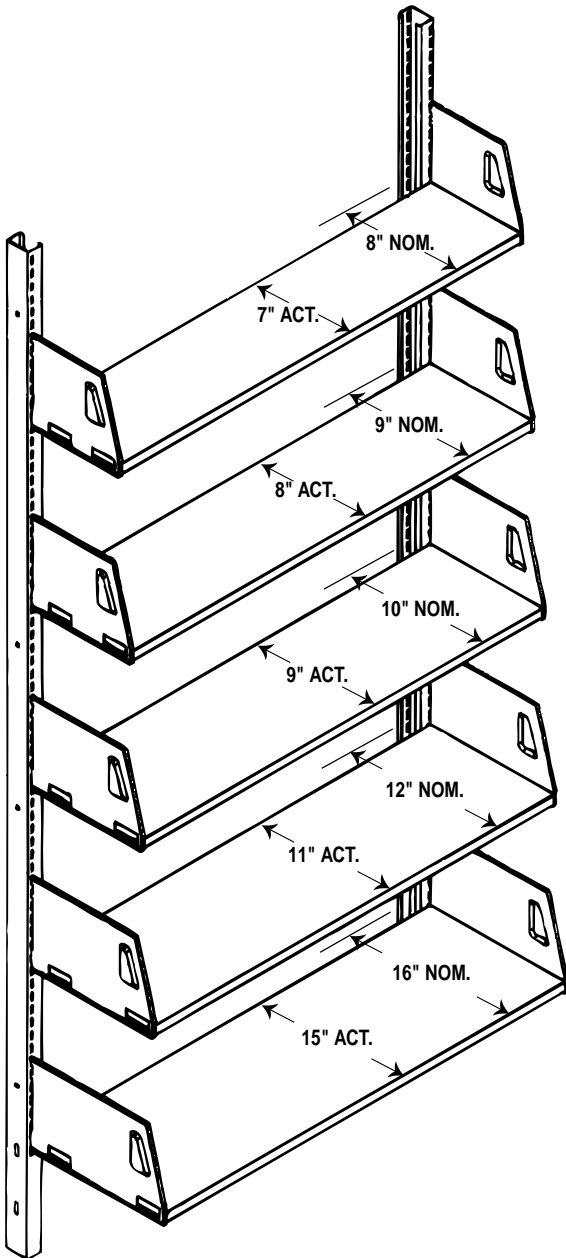

Standard Widths

Nominal Depth	36" Wide Unit No.	30" Wide Unit No.
8"	M68	M08
9"	M69	M09
10"	M610	M010
12"	M612	M012
16"	M616	M016

# ADJUSTABLE DIVIDER SHELVES

**Brackets 16 Gauge • Shelves 18 Gauge**  
**Dividers 18 Gauge 6" (standard) or 10" high**  
**Standard Widths: 36", 30" & 24"**

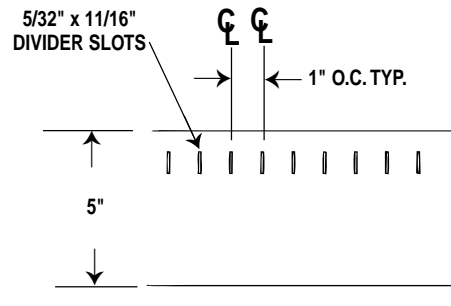
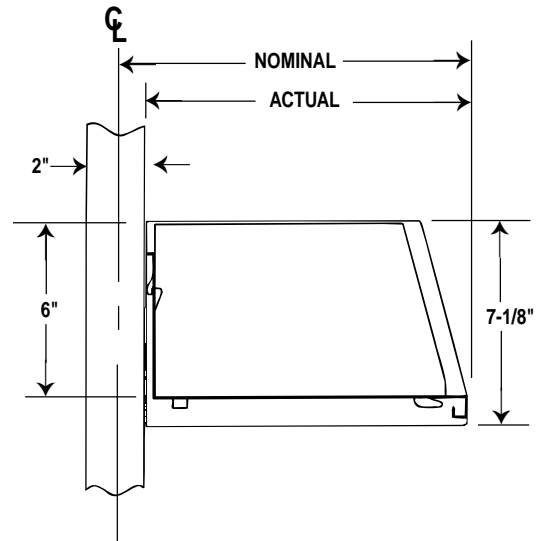
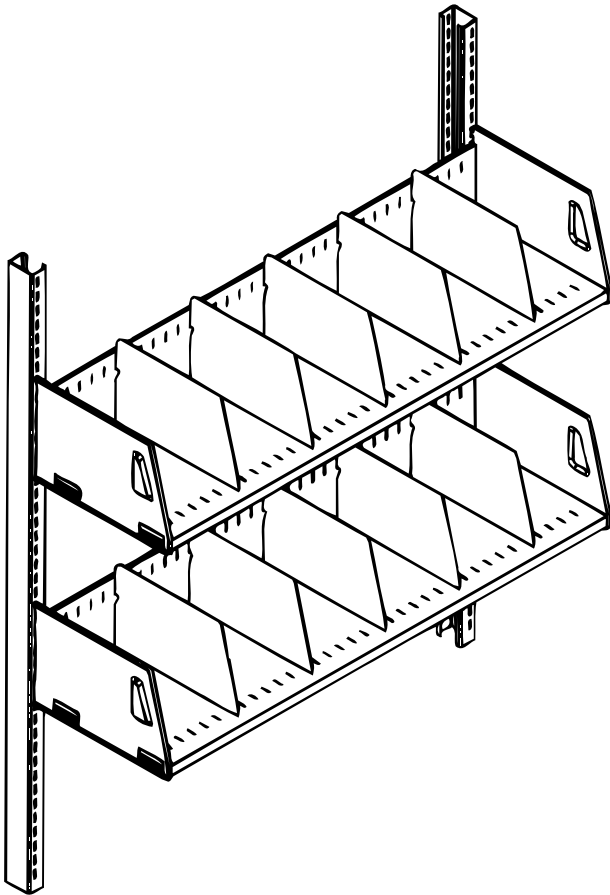

Standard Widths

Nominal Depth	36" Wide Unit No.	30" Wide Unit No.
10"	MD610	MD010
12"	MD612	MD012
14"	MD614	MD014

36" wide - 5 dividers per shelf as shown  
 30" wide - 4 dividers per shelf

# SHELF EXTENSION

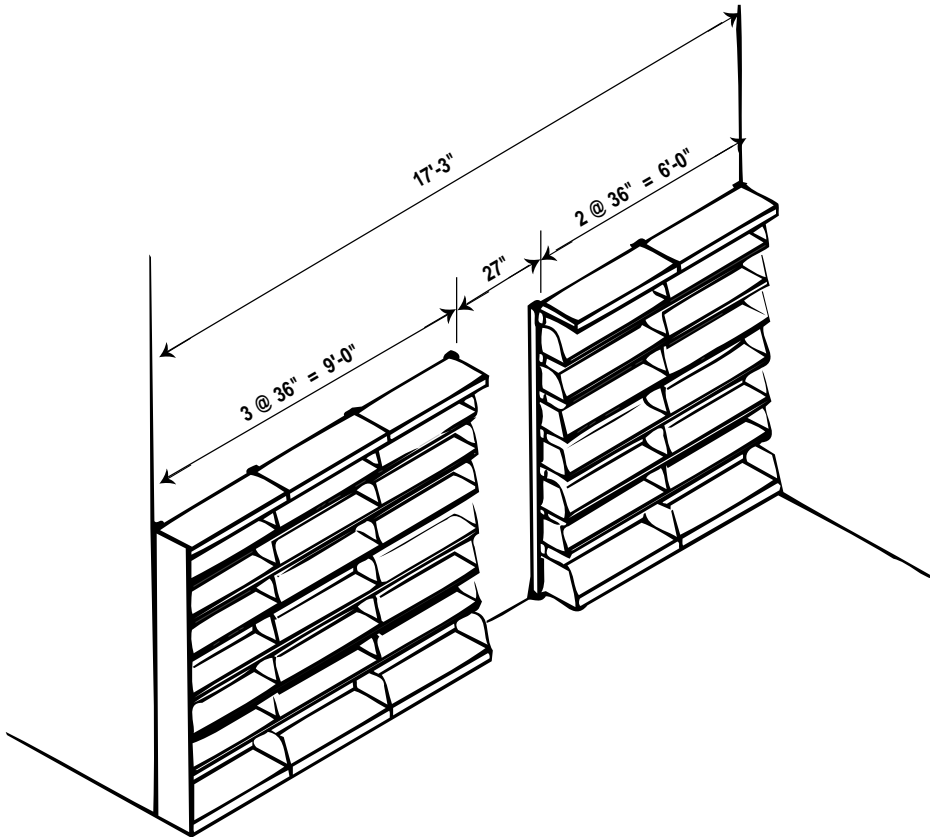

**NOTE:**

1. Shelf Extension allows user to create special width units less than 36" without prior field measurements.
2. Shelf Extensions are for standard adjustable shelves, and standard closed base shelves without integral backs.

**EXAMPLE:**

1. User has unfinished wall where finished dimension is approximately 17'-0"±
2. User orders 15'-0" standard shelving (5 - 36" units) + extension parts for one unit.
3. Finished wall = 17'-3". User cuts extension parts to accommodate 27" space.

## TOP VIEW

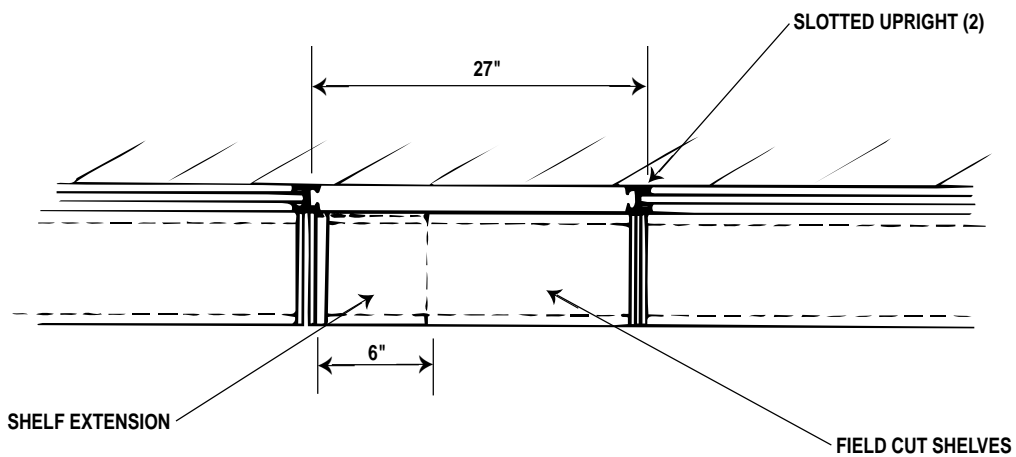

# EXTENSION COMPONENTS

## STEEL CANOPY TOPS

Tops furnished in 36" length, single faced or double faced. Cut in field to proper dimension. Insert canopy top extension component. Affix to canopy top brackets.

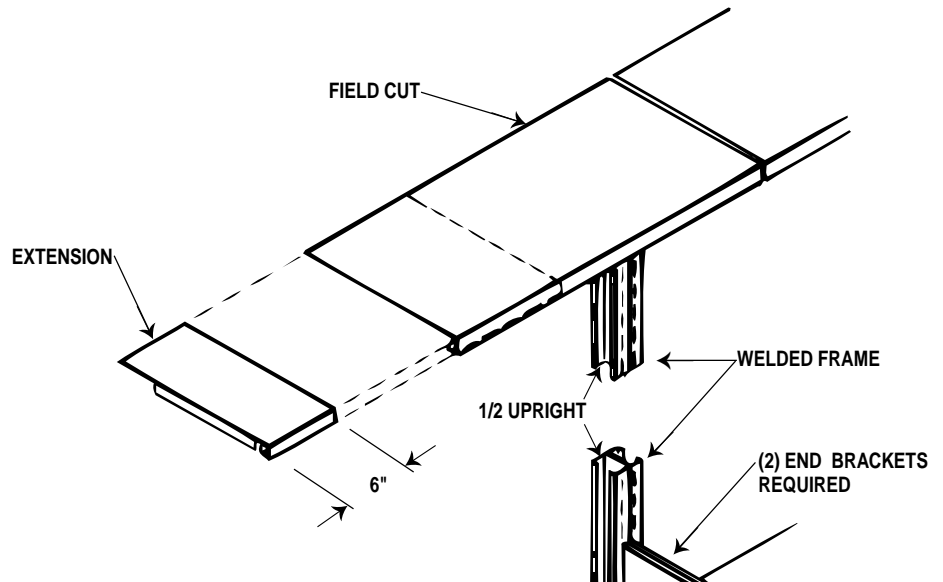

## ADJUSTABLE SHELVES

Shelves furnished in 36" length. Cut in field to proper dimension. Insert shelf extension component. Affix shelf to end brackets.

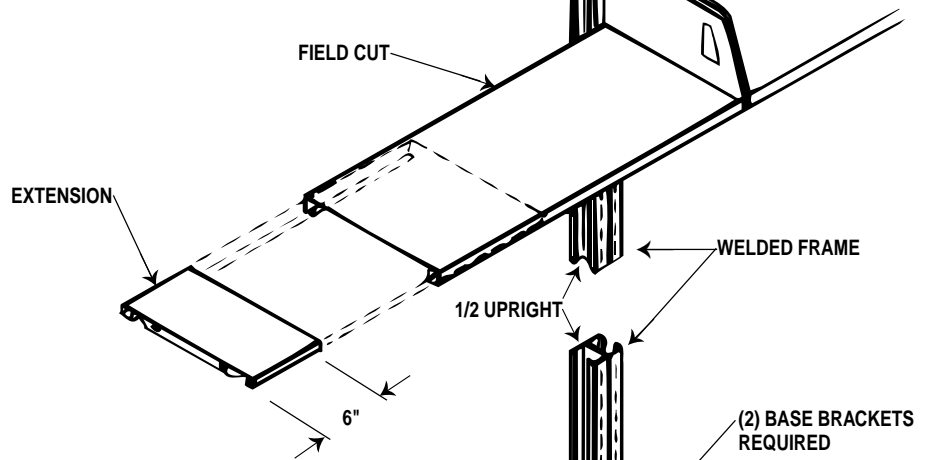

## BASE SHELVES

Bases furnished in 36" length. Cut in field to proper dimension. Insert base extension component. Affix base to base brackets.

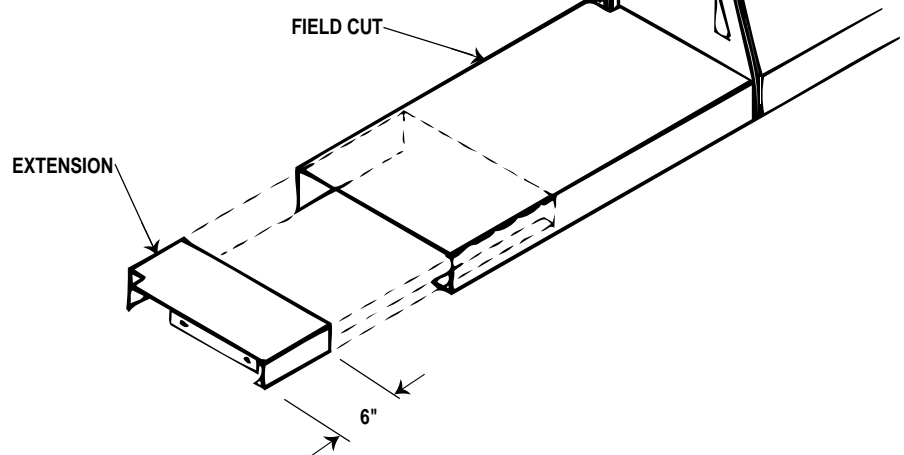

**NOTE:** Other components necessary include 1/2 upright and top spreader (available for bolt in installation).

# HINGED PERIODICAL SHELVES

16" & 12" Shelves 18 Gauge • Pivots & Brackets 16 Gauge

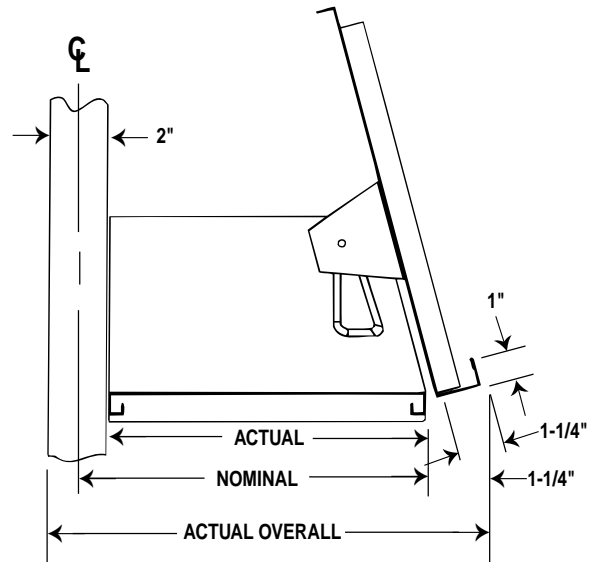
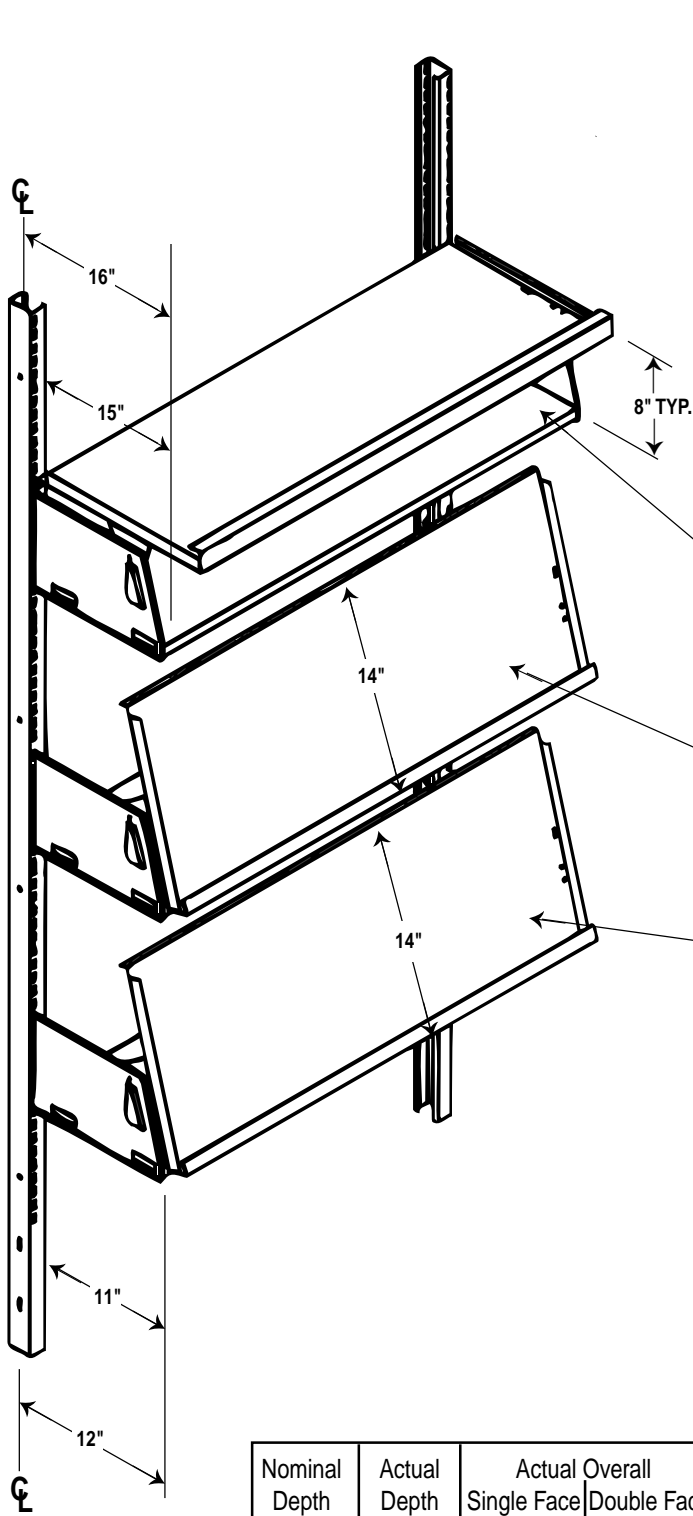

**16" DEEP HINGED PERIODICAL SHELF PAN**

Unit No. - MHP614N - Raised position

**16" DEEP HINGED PERIODICAL SHELF PAN**

Unit No. - MHP614N - Normal position

**12" DEEP HINGED PERIODICAL SHELF PAN**

Unit No. - MHP614 - Normal position

## GENERAL INFORMATION - HINGED PERIODICAL SHELVES

1. When single faced hinged periodical shelves are used, and ranges terminate into a corner, to assure proper clearances for hinged shelf pan operation, a minimum of 2" should be added to the nominal shelf depth for corner fillers.

Example: C.F. 90 x 14 x 14 (See Corner Filler for additional information).

2. When end panels are required to fully capture the entire profile of hinged periodical shelves, add 3" to nominal single face shelf depth and 4" to nominal double face shelf depth.

Example: (A) A 12" nominal depth hinged periodical unit requires a 15" minimum depth end panel; (B) a 24" nominal depth unit requires a 28" minimum depth end panel.

3. Divider shelves with 6" high dividers are optional. Contact factory for additional information.

Nominal Depth	Actual Depth	Actual Overall	
		Single Face	Double Face
12"	11"	14-5/8"	25-15/16"
16"	15"	18-5/8"	34-15/16"

# HINGED PERIODICAL SHELVES WITH PLEXIGLASS COVERS

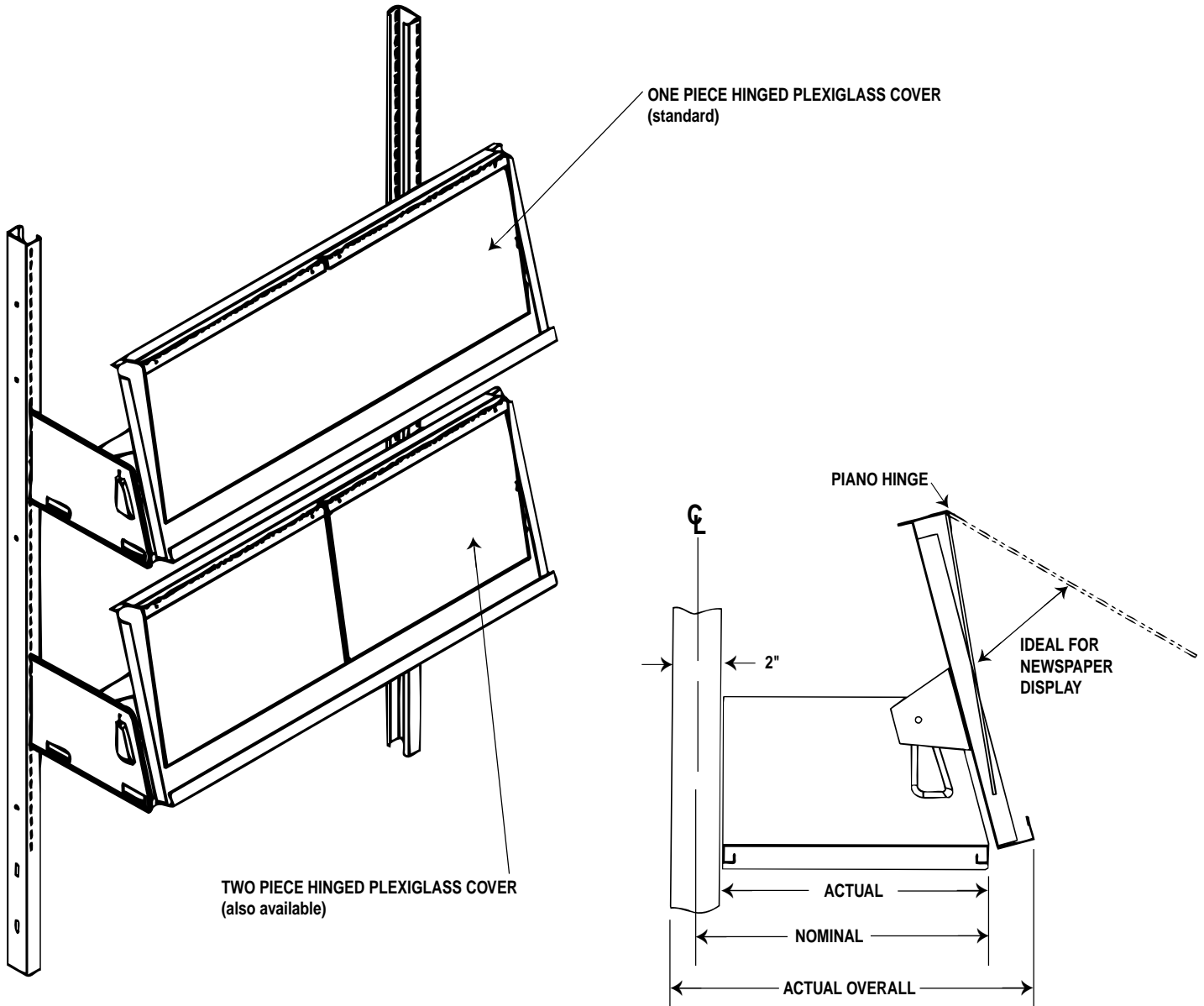

## HINGED PERIODICALS WITH PLEXIGLASS COVERS

1. All dimensions for hinged periodical shelf with plexiglass are same as hinged periodical shelf.
2. Plexiglass covers are 1/8" thick clear plexiglass with a 1/16" bevel on (3) edges for a finished appearance and to prevent chipping. Hinged periodical pans are furnished with piano type hinges along top edge of pan to allow easy removal of displayed materials.

# FIXED PERIODICAL SHELVES

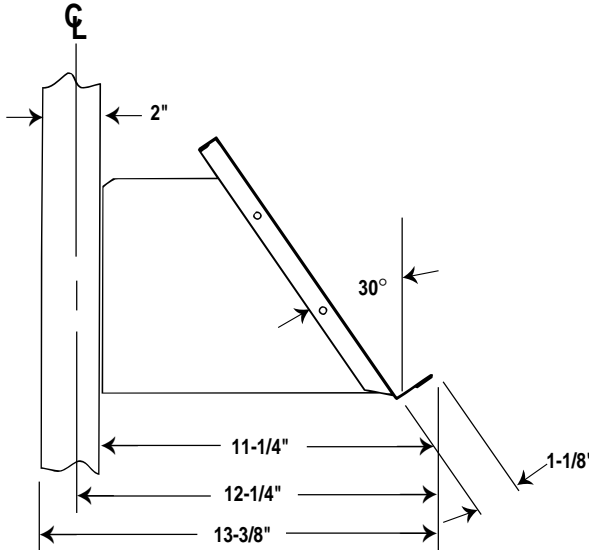
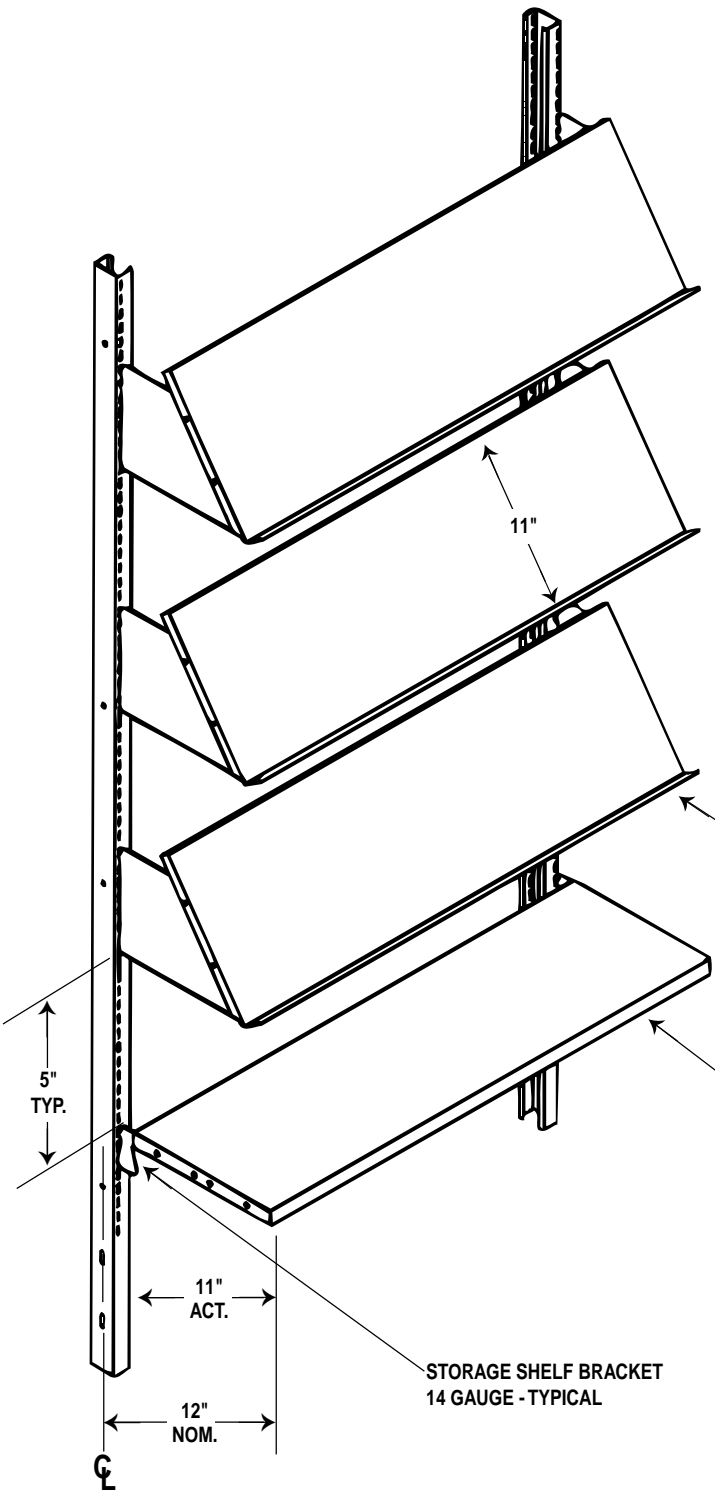

FIXED PERIODICAL SHELF  
18 GAUGE STEEL  
and  
BRACKETS  
16 GAUGE STEEL

STORAGE SHELF  
18 GAUGE STEEL

STORAGE SHELF BRACKET  
14 GAUGE - TYPICAL

Description	36" Wide Unit No.	30" Wide Unit No.
Fixed Periodical Storage Shelf	MFP612 MS612	MFP012 MS012

# BOOK DISPLAY UNIT

Bottom two shelves of the book display unit are sloped back at a 10° angle for better visibility of contents on bottom shelves.

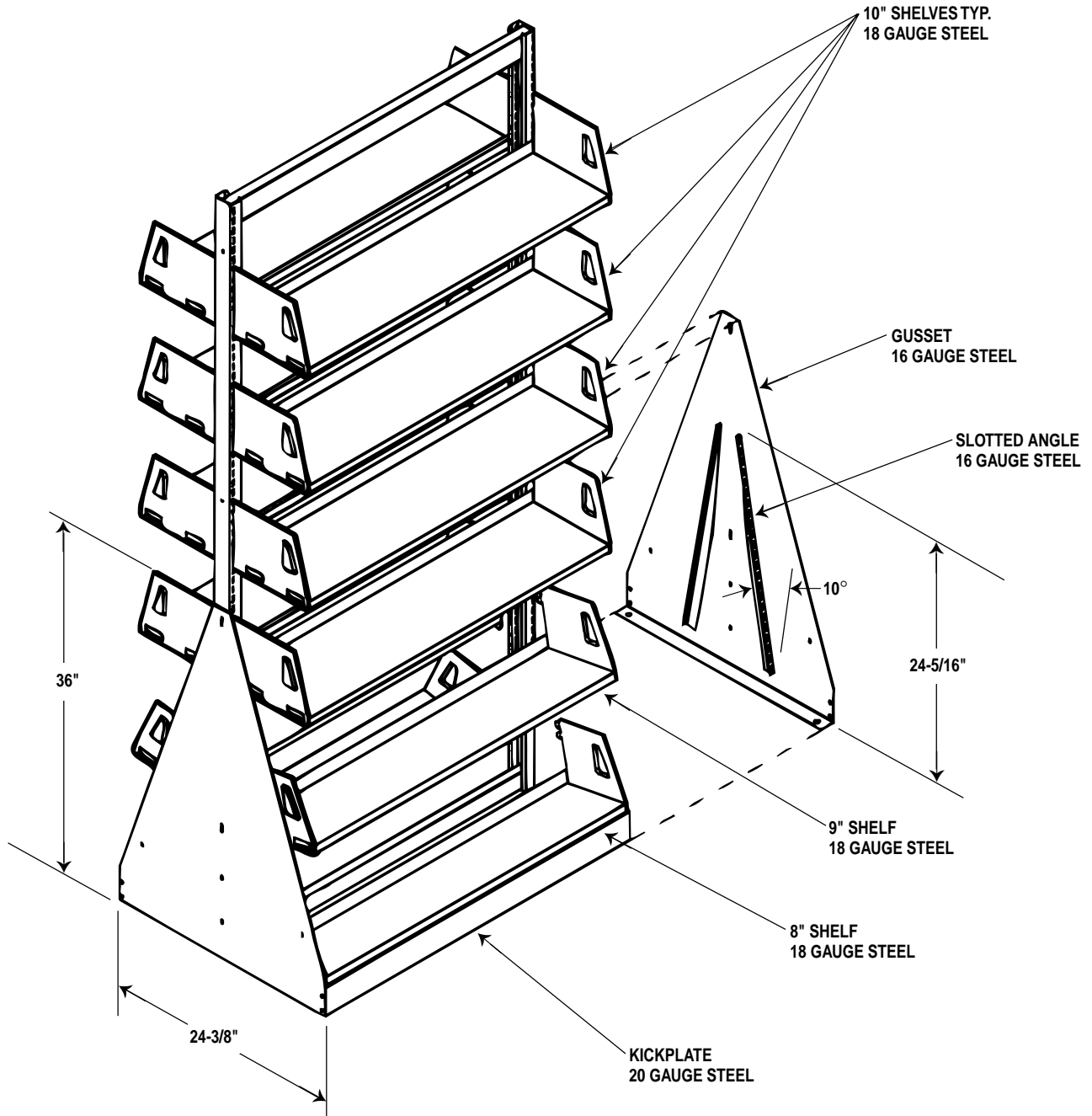

Unit Depth	36" Wide Unit No.		30" Wide Unit No.		24" Wide Unit No.	
	Starter	Adder	Starter	Adder	Starter	Adder
66"	MBDS66DF	MBDA66DF	MBDS06DF	MBDA06DF	MBDS46DF	MBDA46DF
78"	MBDS67DF	MBDA67DF	MBDS07DF	MBDA07DF	MBDS47DF	MBDA47DF
90"	MBDS69DF	MBDA69DF	MBDS09DF	MBDA09DF	MBDS49DF	MBDA49DF

# SPECIAL PURPOSE SHELVES

## CASSETTE SHELF - DOUBLE TIER



36" Unit No.	30" Unit No.
MACSDT-36	MACSDT-30

## CASSETTE / MICROFILM SHELF

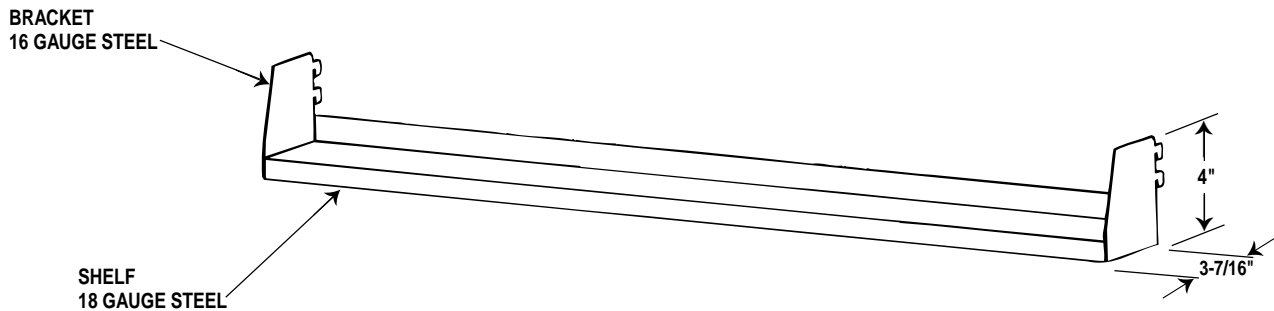

36" Unit No.	30" Unit No.
MMF64	MMF04

**NOTE:**

1. Actual shelf depth is 3-1/2".
2. Shelf and backstop constructed of one integral piece.
3. Bracket and shelf are one welded assembly.

# SPECIAL PURPOSE SHELVES

## MEDIA SHELF - DOUBLE TIER

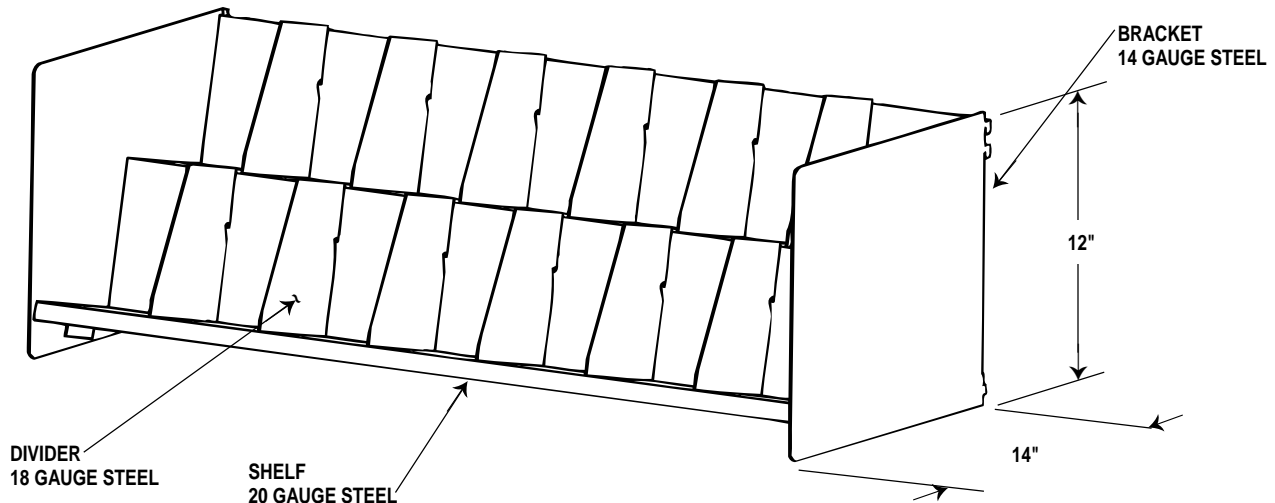

36" Unit No.	30" Unit No.
MCDSDT-36	MCDSDT-30

36" unit provided with 6 dividers per level.  
Capacity: 60 VHS/Beta or 160 Compact Discs.

### ADJUSTABLE DIVIDER

Unit No. - 31091-001

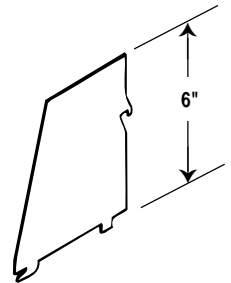

## MEDIA SHELF - SINGLE TIER

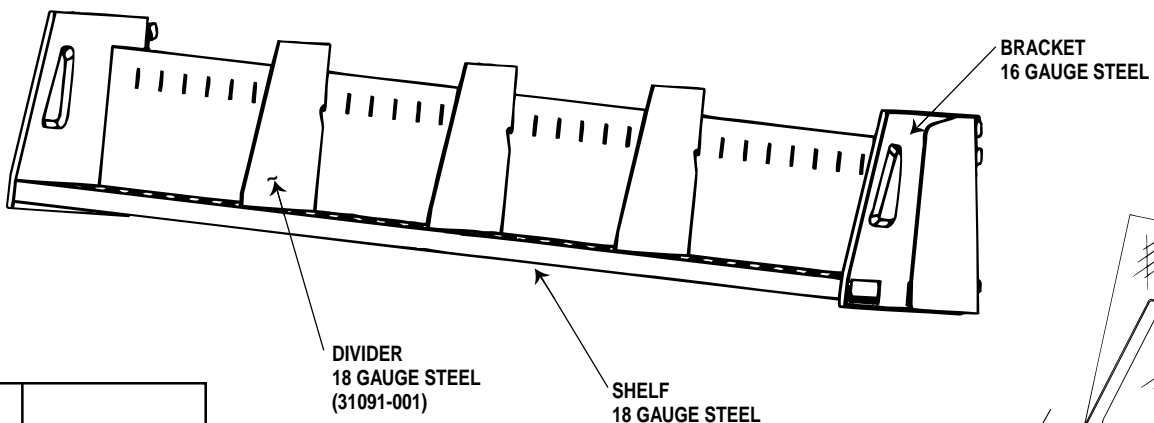

36" Unit No.	30" Unit No.
MSAVS-636	MSAVS-630

36" unit provided with 3 dividers.  
Capacity: 30 VHS/Beta or 80 Compact Discs.

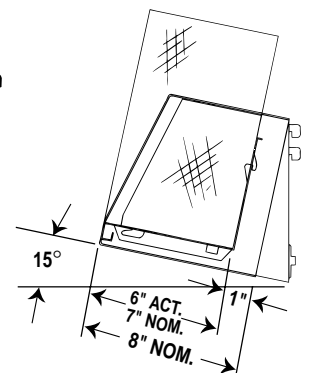

NOTE: When using MEDIA SHELF - SINGLE TIER:

1. The base shelf required to match sloped shelf projection is 9" nominal for single face and 18" nominal for double face.
2. Steel end panels required for the coverage of sloped shelf are 9" nominal for single face and 18" nominal for double face.

# SPECIAL PURPOSE SHELVES

## ZIG ZAG PAPERBACK SHELF

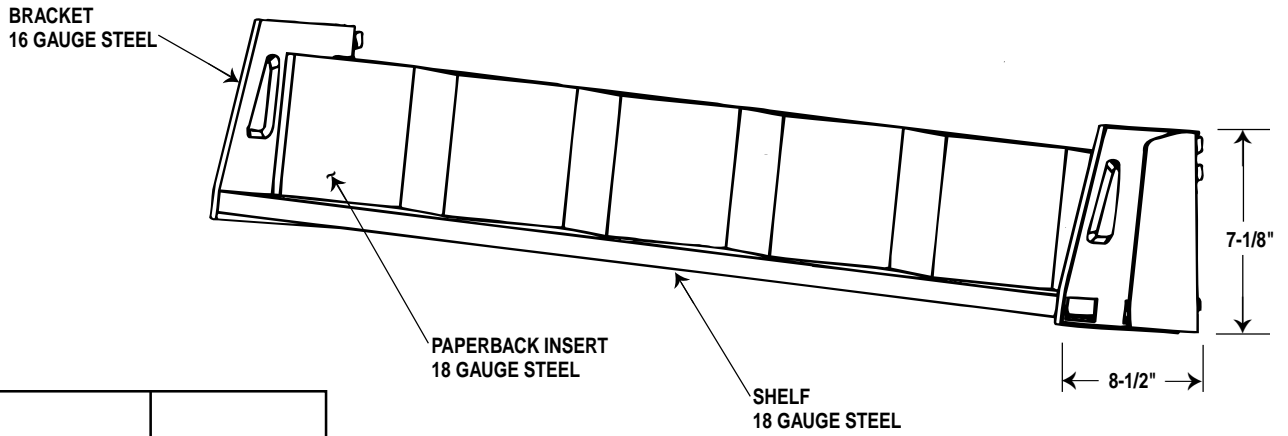

36" Unit No.	30" Unit No.
MZIGZAG-36	MZIGZAG-30
Insert Unit No.	X
31101-035	X

---



---

## MEDIA HANGER RACK

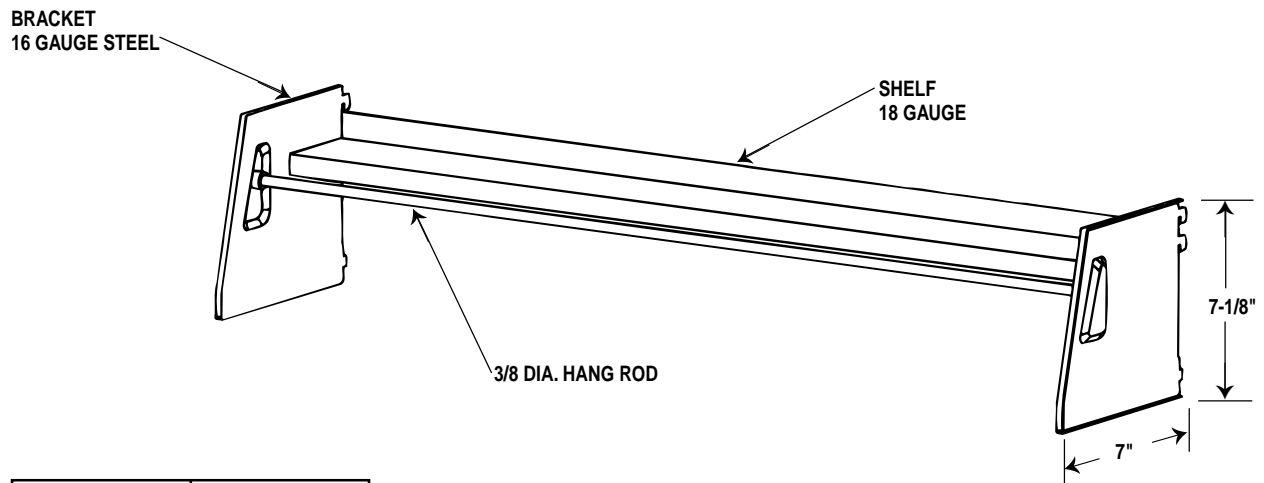

36" Unit No.	30" Unit No.
MPBAGH-36	MPBAGH-30

# SPECIAL PURPOSE SHELVES

## MULTI-MEDIA BROWSING BOX

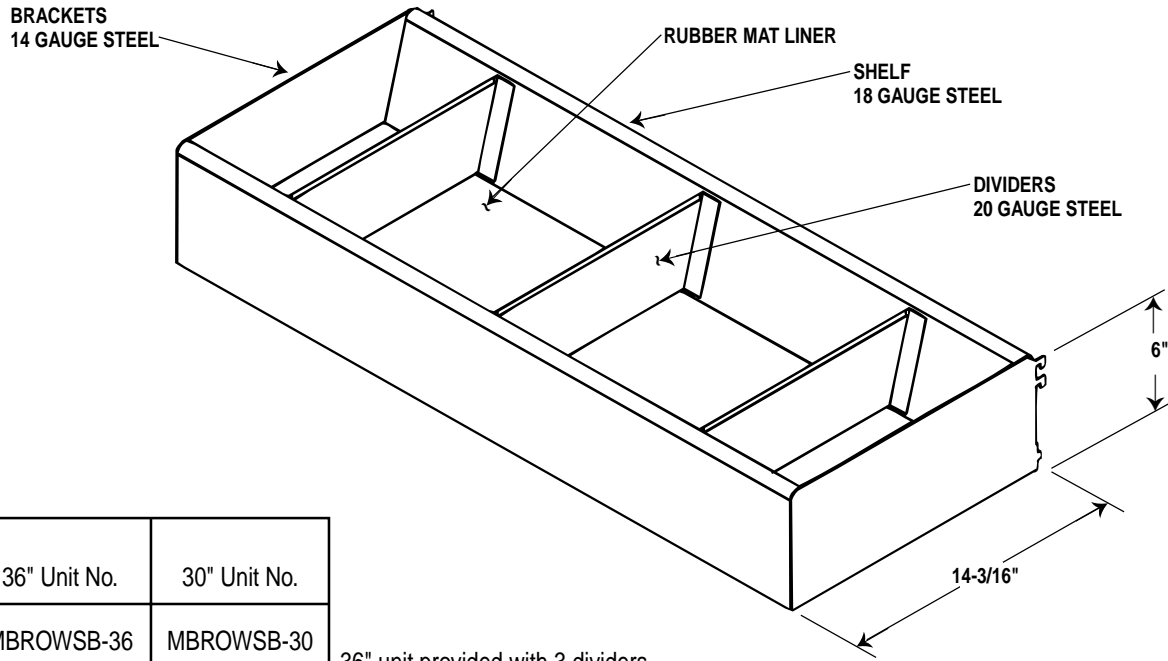

## BASE MULTI-MEDIA BROWSING BOX

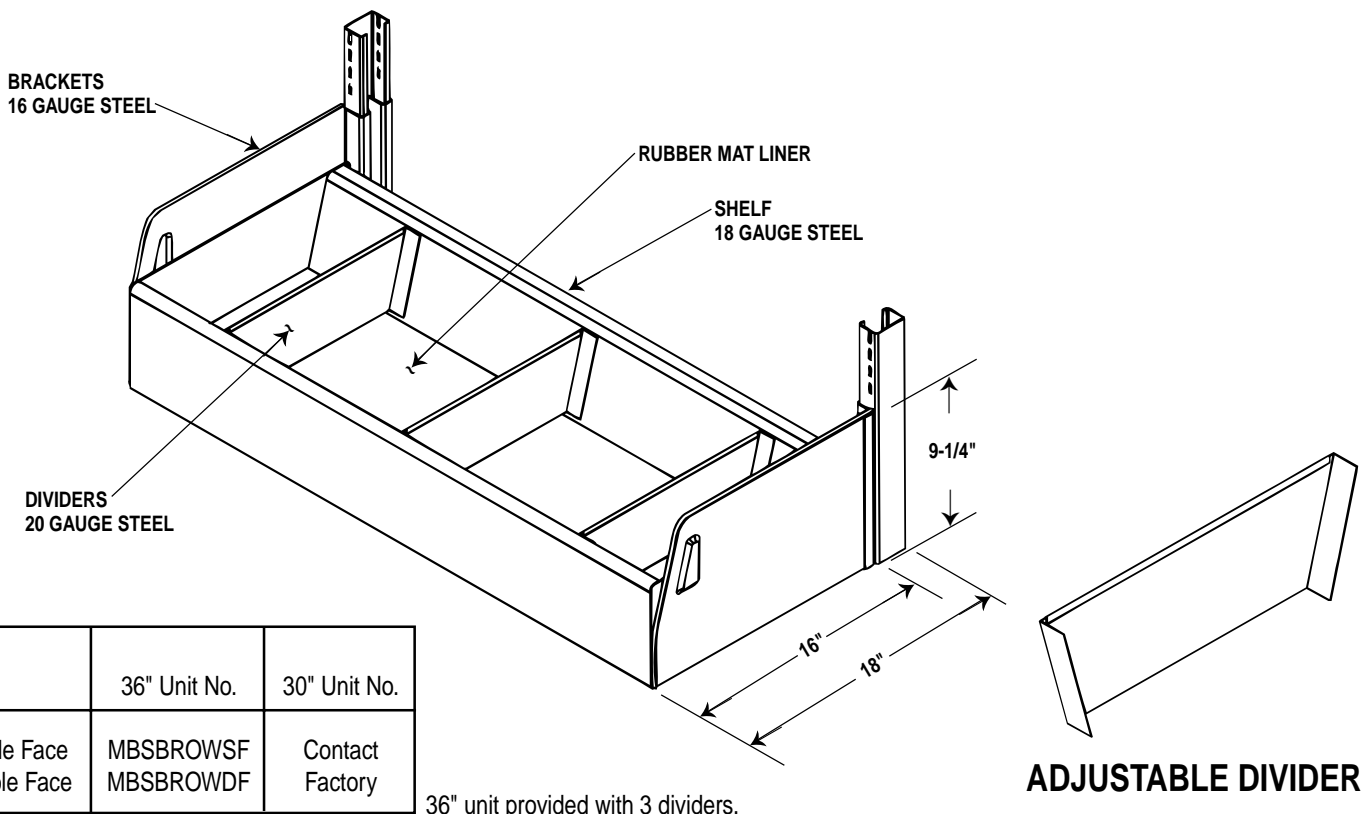

# SPECIAL PURPOSE SHELVES

## COMPACT LOW PROFILE BROWSING BOX

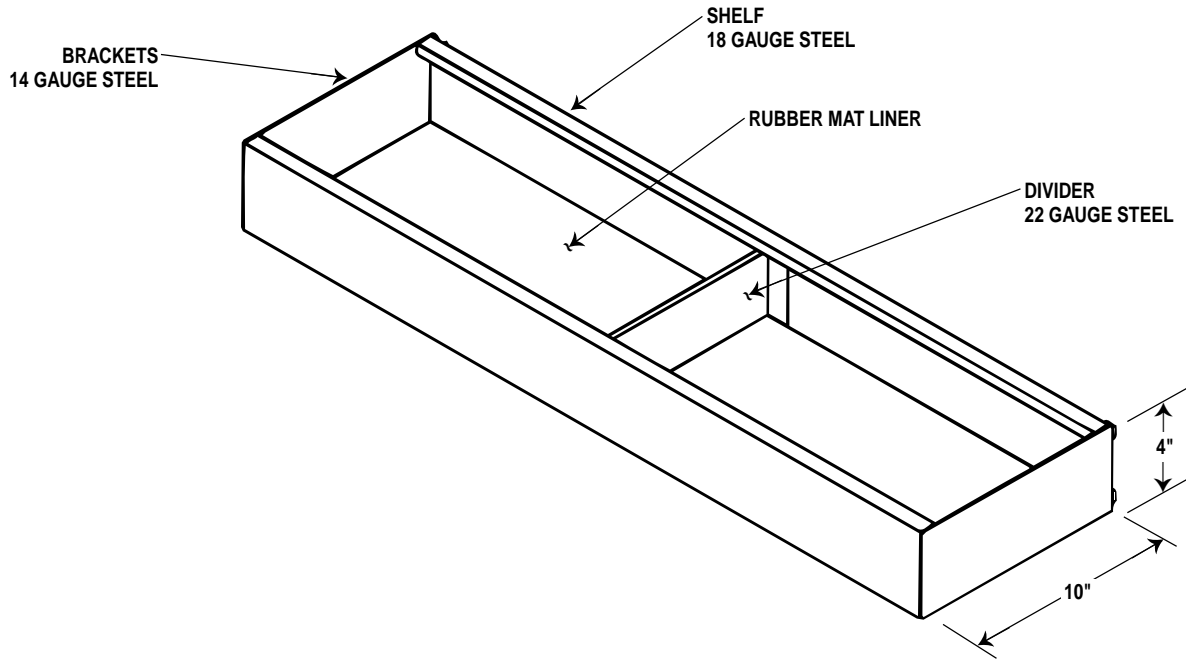

36" Unit No.	30" Unit No.
MBOXLOPRO	Contact Factory

Standard units provided with 6 dividers.

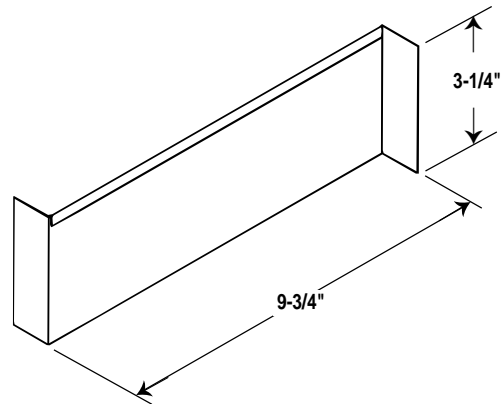

### ADJUSTABLE DIVIDER

Unit No. - 31090-006

# CONSULTATION SHELF

Designed to permit in-stack work area or full depth filing.

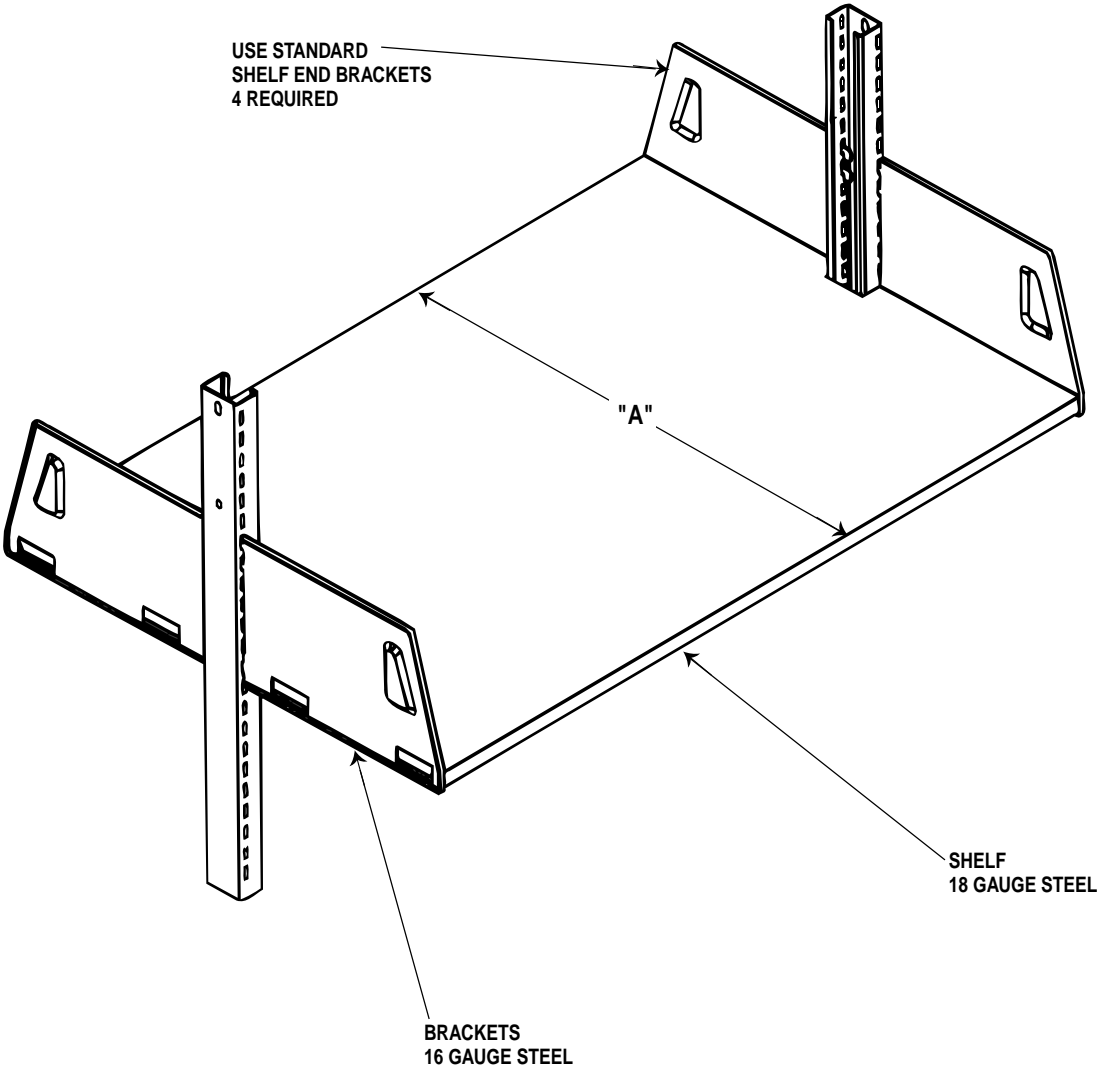

"A"
20" Nominal 24" Nominal

For use with standard double faced units 20" and 24" deep only.

# WORK SHELF

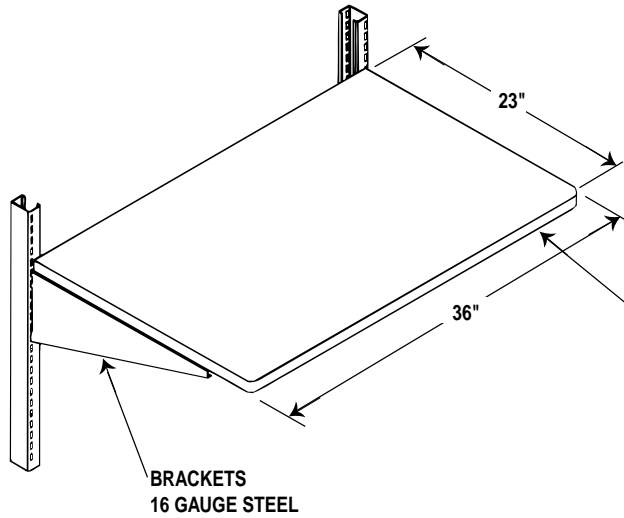

Unit No. - MWS624

HIGH PRESSURE LAMINATED SURFACE 1-1/4" X 23" X 36"  
OVER 45 POUND MEDIUM DENSITY INDUSTRIAL GRADE  
PARTICLE BOARD.

BRACKETS  
16 GAUGE STEEL

# HEAVY DUTY STORAGE SHELF

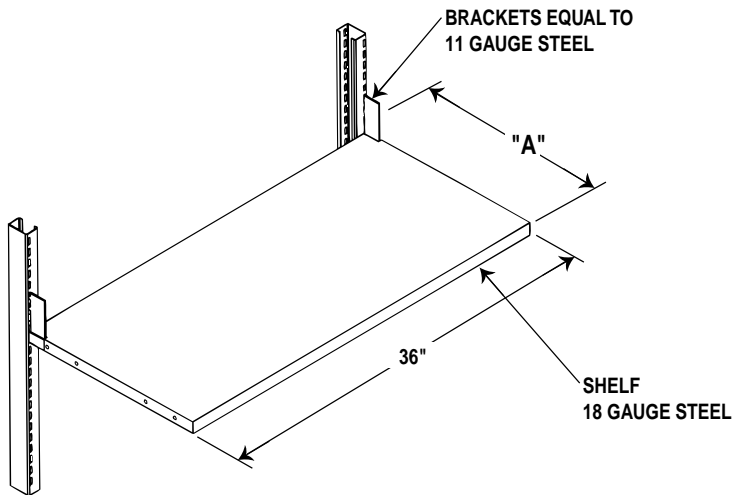

Actual	"A"	Unit No.
	Nominal	
17"	18"	MS618 Contact Factory
23"	24"	

# STORAGE SHELF

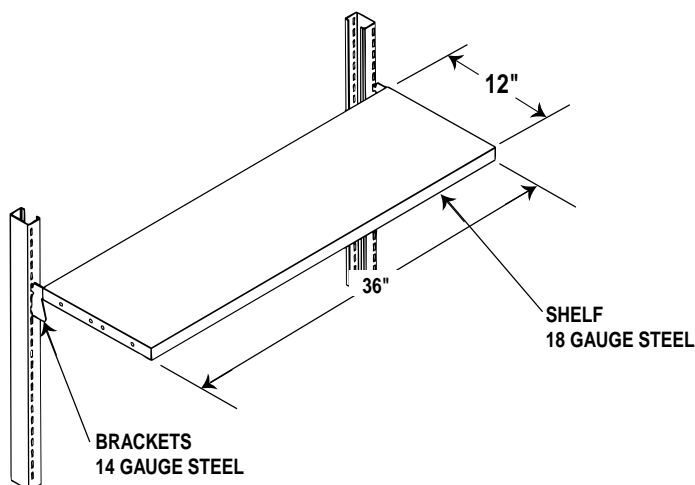

Use with any frame or wall column strip, with  
fixed periodical shelves, or any place where a  
flat shelf is desired.

Unit No. - MS612

# SLIDING REFERENCE SHELF

Single Entry • Shelves 18 Gauge

Standard Widths: 36" & 30"

Standard Depths: 8", 9", 10" & 12"

All sliding reference shelves are flush with front of adjustable shelf when retracted.

All sliding reference shelves are single entry design.

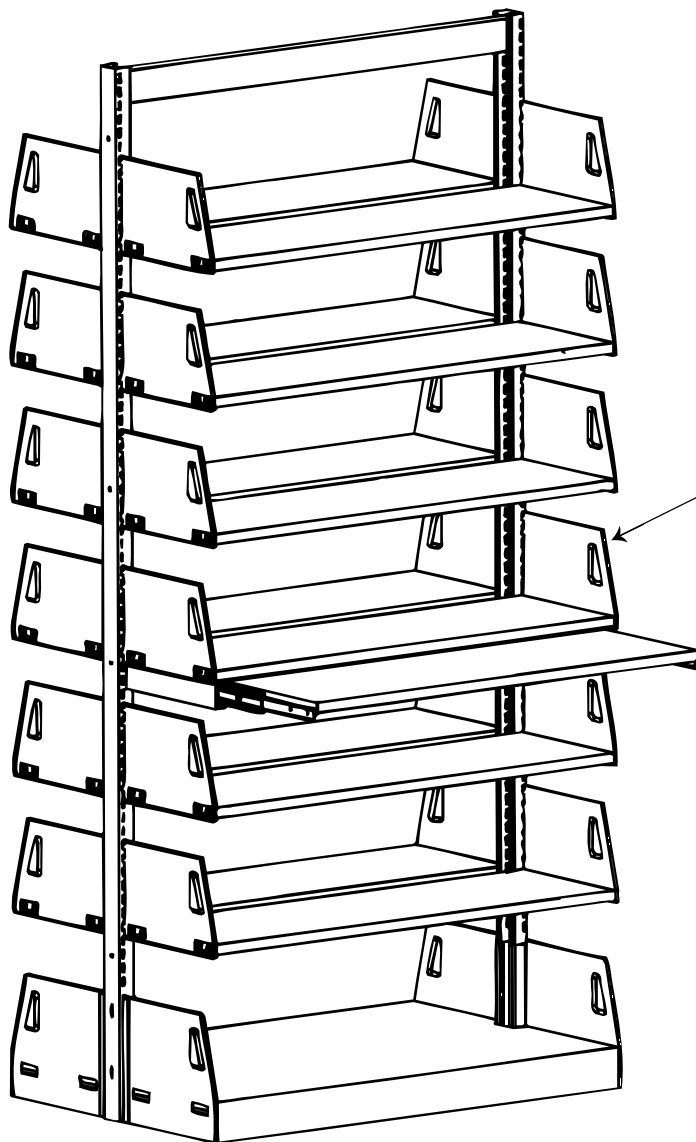

STANDARD SHELF

PULL-OUT REFERENCE SHELF

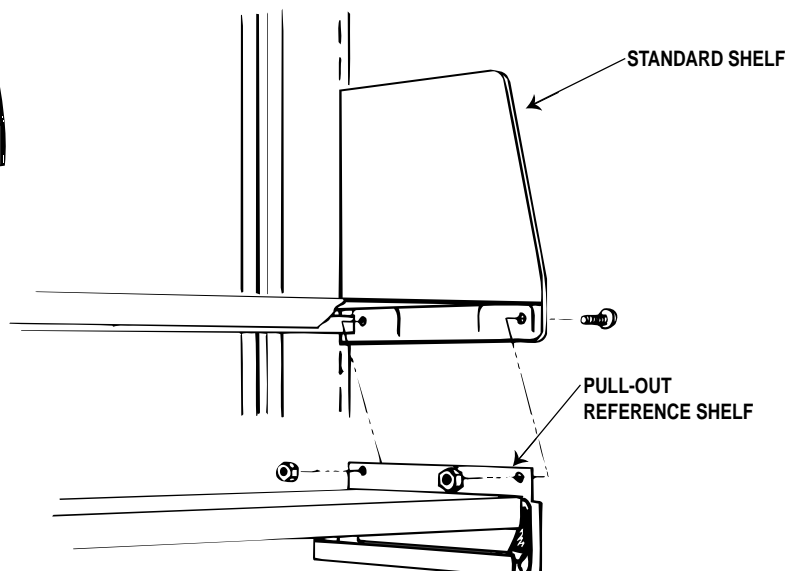

STANDARD SHELF

PULL-OUT REFERENCE SHELF

# BOOK SUPPORTS

## FINDABLE BOOK SUPPORT

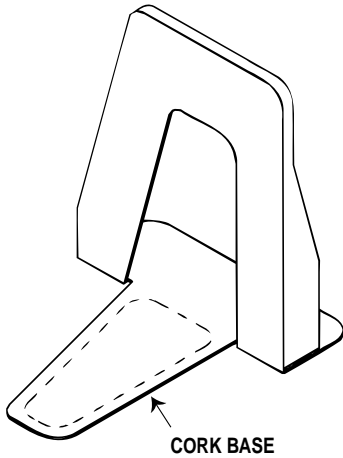

6" high Unit No. - 31330-030

9" high Unit No. - 31330-040

Also available with magnetic base.

18 gauge steel

---

---

## HOOK-ON BOOK SUPPORT

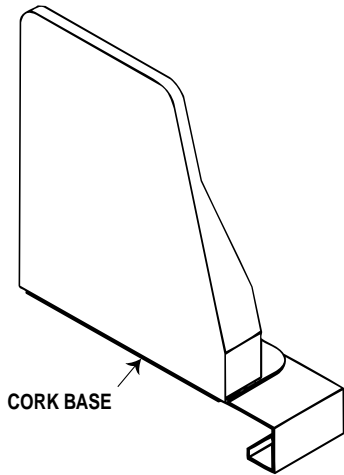

6" high Unit No. - 31330-010

9" high Unit No. - 31330-020

18 gauge steel

---

---

## WIRE BOOK SUPPORT

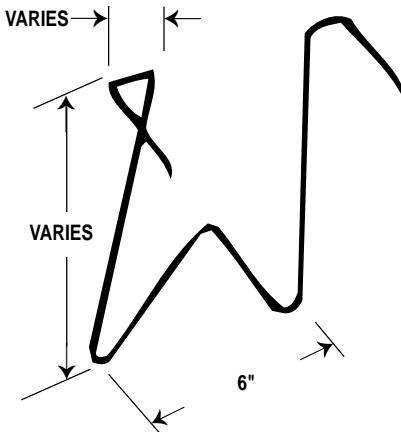

To fit shelves 8" and 9" deep nominal: Unit No. - 00946-030

To fit shelves 10" and 12" deep nominal: Unit No. - 00946-040

To fit shelves 16" deep nominal: Unit No. - 00946-041

3/16 spring wire; galvanized; zinc plated.

# ADJUSTABLE SHELF DIVIDERS

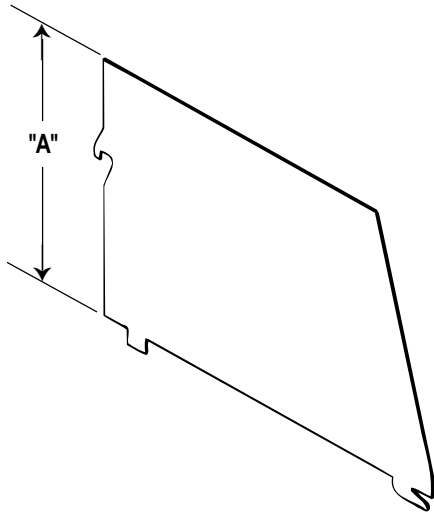

"A"	Nominal Shelf/Base Depth	Unit No.
6"	10"/10"	31090-010
6"	10"/12"	31090-010
6"	12"/12"	16092-001
6"	14"/16"	31090-040
10"	10"/10"	31090-050
10"	10"/12"	31090-050
10"	12"/12"	31090-060
10"	14"/16"	31090-070

For use with all divider-type shelves.

NOTE: 6" high dividers are standard with divider shelves and divider-type units.

18 gauge steel.

# SLIDING BOOK SUPPORTS®

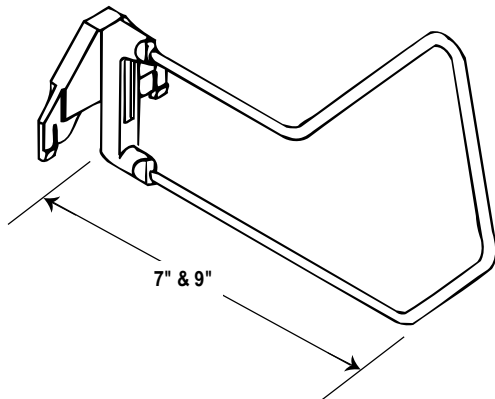

Nominal Shelf Depth	Unit No.
8"	31090-000
9"	31090-000
10"	31090-001
12"	31090-001

For use with all integral back shelves, sliding support back stops and sliding support center stops.

# ADJUSTABLE SHELF BACKSTOPS

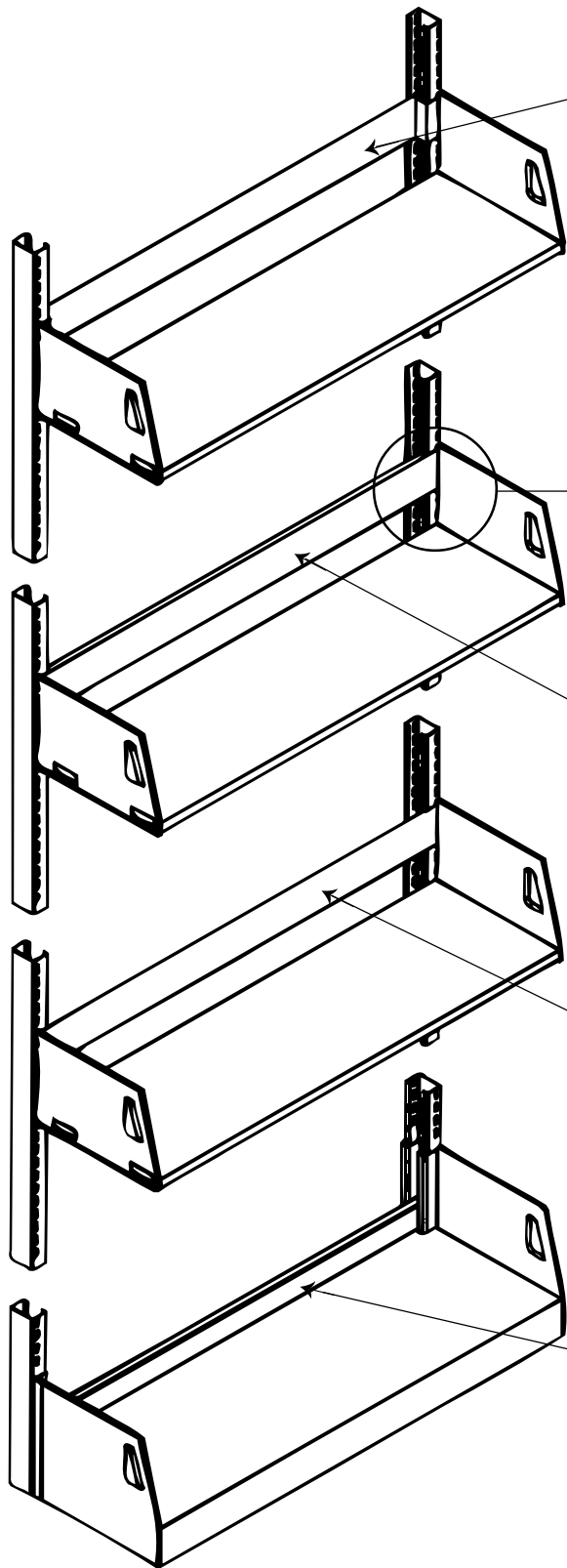

## ADJUSTABLE SHELF CENTER BACKSTOP

36" Unit No.	30" Unit No.
31101-020	31101-025

16 gauge steel

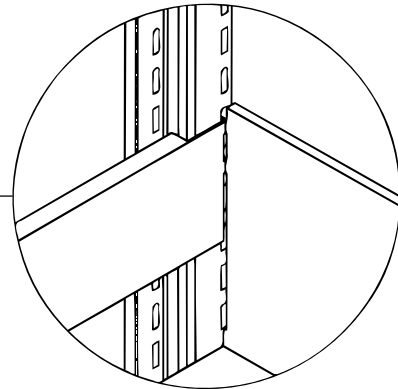

Backstops can use same slots as shelf brackets.

## ADJUSTABLE SHELF BACKSTOP

36" Unit No.	30" Unit No.
31100-030	31100-020

18 gauge steel

## SLIDING SUPPORT BACKSTOP

36" Unit No.	30" Unit No.
31101-010	31101-000

18 gauge steel

## SLIDING SUPPORT CENTERSTOP

36" Unit No.	30" Unit No.
31110-012	31110-010

Extruded aluminum

NOTE: Sliding support backstops and centerstops allow the use of Wilsonstak® patented sliding book supports. See page 38.

Sliding support centerstops are for base shelves only.

# STEEL END PANELS

For Closed Bases  
(also available for wall hung columns)

SINGLE FACED			DOUBLE FACED		
Unit Height "A"	Nominal Base Depth "B"	Unit No.	Unit Height "A"	Nominal Base Depth "B"	Unit No.
42"	8"	31120-010	42"	16"	31122-055
	9"	31120-045		18"	31122-090
	10"	31120-080		20"	31123-025
	12"	31121-015		24"	31123-060
	16"	31122-000		32"	31124-045
66"	8"	31120-020	66"	16"	31122-065
	9"	31120-055		18"	31123-000
	10"	31120-090		20"	31123-035
	12"	31121-025		24"	31123-070
	16"	31122-010		32"	31124-055
78"	8"	31120-025	78"	16"	31122-070
	9"	31120-060		18"	31123-005
	10"	31120-095		20"	31123-045
	12"	31121-030		24"	31123-075
	16"	31122-015		32"	31124-060
84"	8"	31120-030	84"	16"	31122-075
	9"	31120-065		18"	31123-010
	10"	31121-000		20"	31123-040
	12"	31121-035		24"	31123-080
	16"	31122-025		32"	31124-070
90"	8"	31120-035	90"	16"	31122-080
	9"	31120-070		18"	31123-015
	10"	31121-005		20"	31123-050
	12"	31121-040		24"	31123-085
	16"	31122-035		32"	31124-080
93"	8"	31120-040	93"	16"	31123-085
	9"	31120-075		18"	31123-020
	10"	31121-010		20"	31123-055
	12"	31121-045		24"	31123-090
	16"	31123-085		32"	31124-085

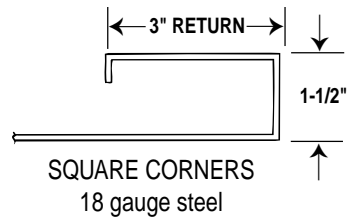
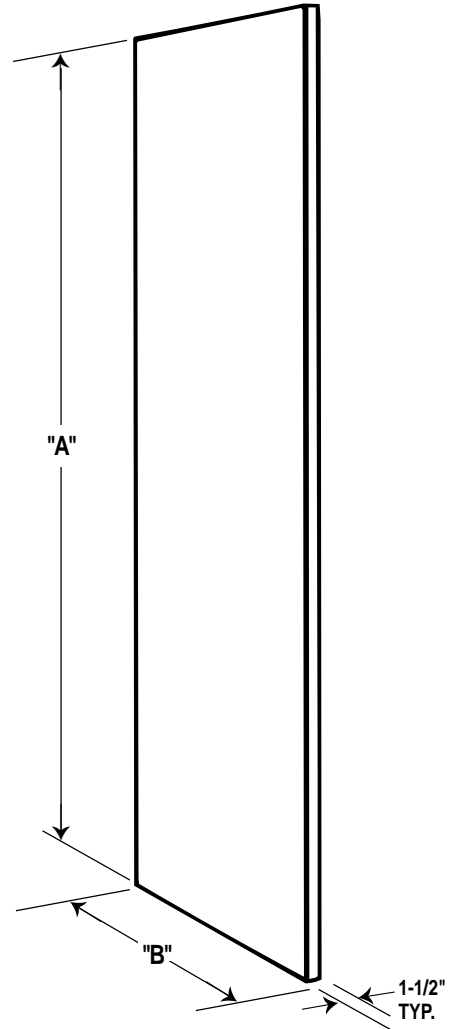

SINGLE FACED



DOUBLE FACED



WALL HUNG COLUMN

Contact factory for wall hung column end panels.

Patterned steel end panels also available.

For wood and laminate end panels, contact factory.

# STEEL END PANELS

For T-Bar Leg Bases

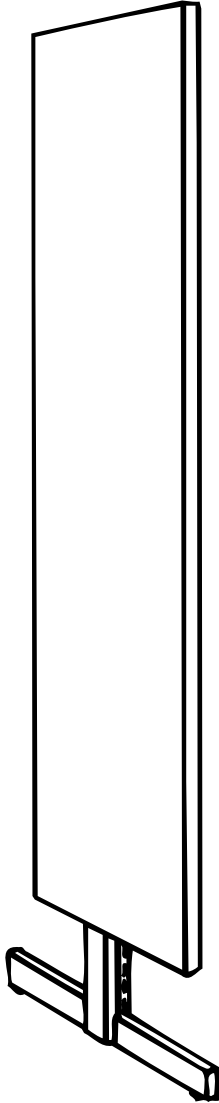

**STEEL T-BAR  
END PANEL**

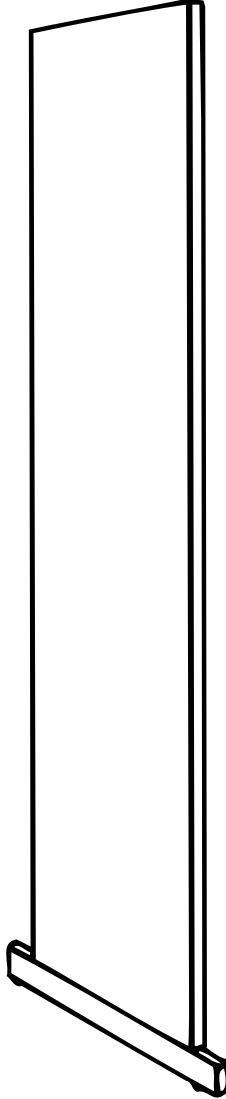

**LAMINATED  
FULL HEIGHT  
END PANEL  
(custom)**

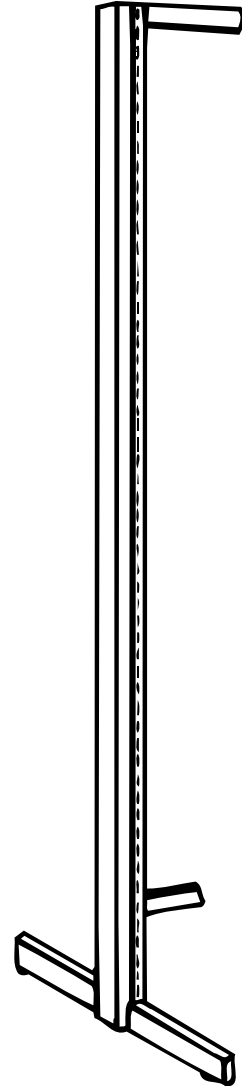

**FULL HEIGHT  
COVER POST**

NOTES:

1. Laminated end panel must be **no less than 1-1/4" thick**.
2. See chart on Page 40 for sizes and unit numbers. Add suffix "T" to unit number when ordering.

# STEEL CANOPY TOPS

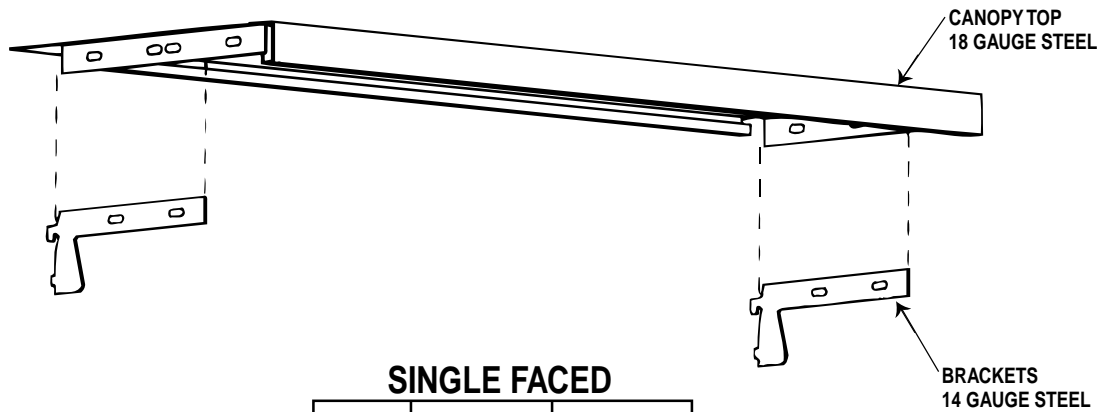

## SINGLE FACED

Nominal Depth	36" Wide Unit No.	30" Wide Unit No.
8"	MC608-SF	MC008-SF
9"	MC609-SF	MC009-SF
10"	MC610-SF	MC010-SF
12"	MC612-SF	MC012-SF
16"	MC616-SF	MC016-SF

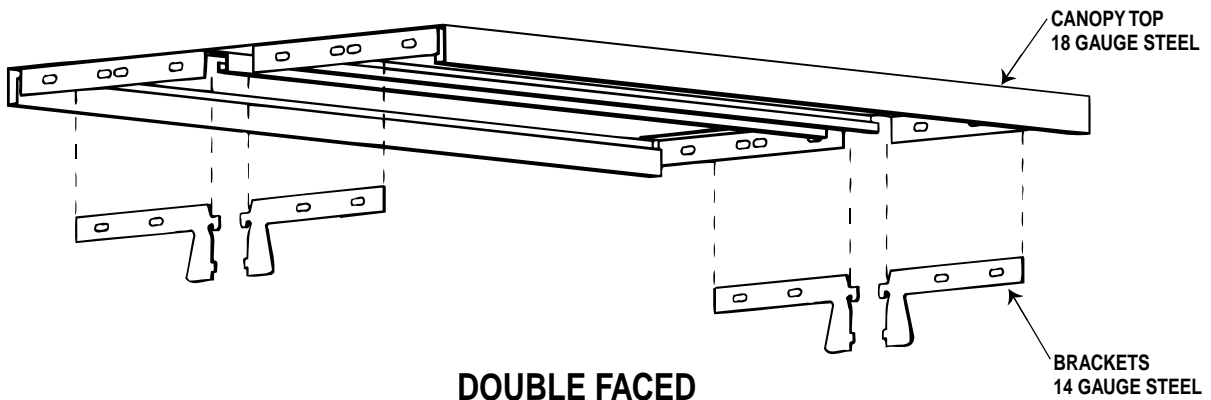

## DOUBLE FACED

Nominal Depth	36" Wide Unit No.	30" Wide Unit No.
16"	MC616-DF	MC016-DF
18"	MC618-DF	MC018-DF
20"	MC620-DF	MC020-DF
24"	MC624-DF	MC024-DF
32"	MC632-DF	MC032-DF

### NOTES:

1. Steel canopy tops are designed to accept wire book supports same as adjustable shelves.
2. Steel tops not recommended for units less than 66" high.
3. Steel canopy top nominal depth should match base shelf nominal depth.

# COUNTER TOPS

For Closed Base or T-Bar Base

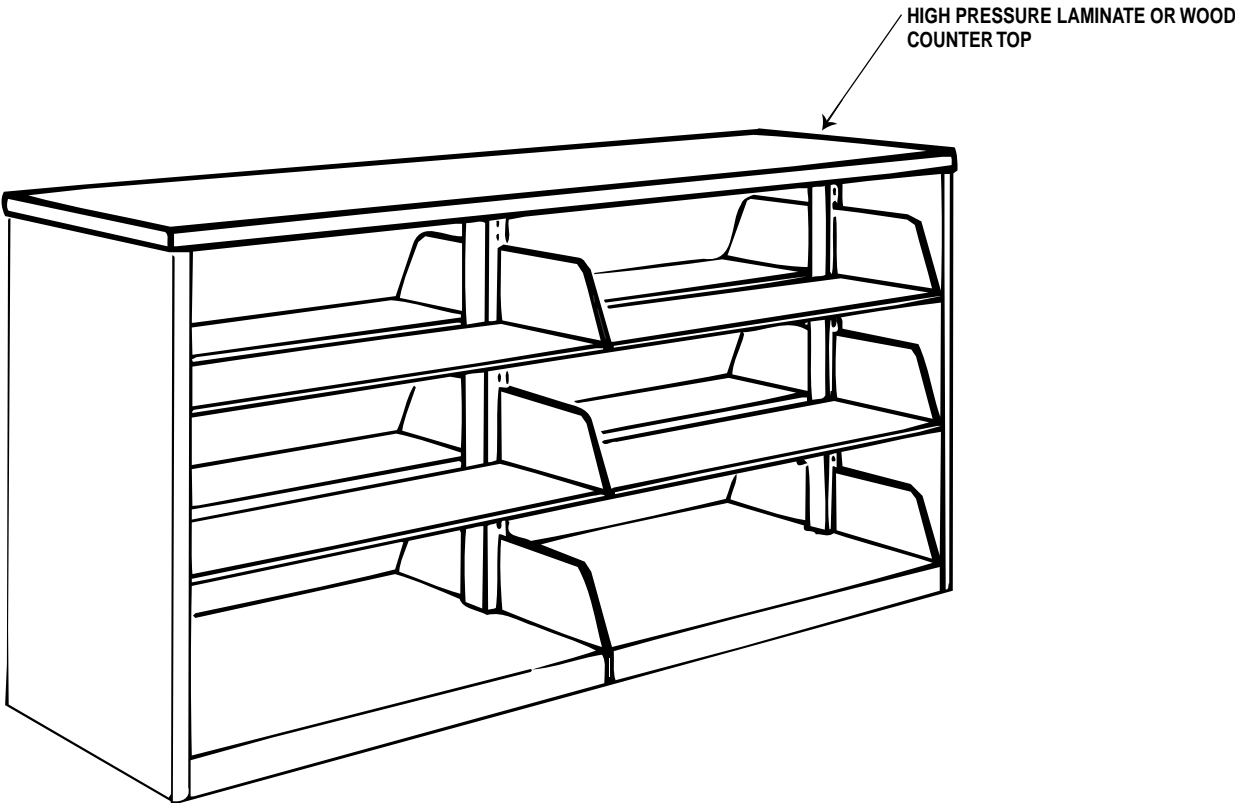

**High Pressure Laminate or Wood Counter Tops** - thickness as specified, particle board, surfaced on one side and all edges. Balancing sheet is applied to underside. When splicing, use loc-tite joint connections at frame intersections.

Recommended for 42", 54", or 66" high units.

Width - as required.

Length - as specified. Formula for figuring length of counter top is: Range Length + 1/16" per Unit + End Panel Thickness + 1".

For Counter Tops captured between end panels, contact factory.

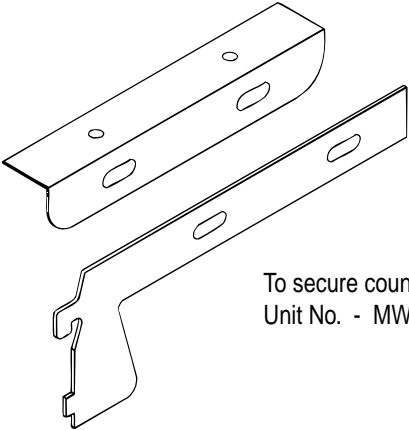

To secure counter top to bookstack units: use the canopy brackets for wood tops.  
Unit No. - MWCB8

# IDENTITY HOLDERS

## 3" x 5" CARD HOLDER

Zinc plated steel or painted card holder used on end panels for row identification. One required for single faced, and two for double faced ranges. Clear plastic cover available.

Unit No. - 00944-000

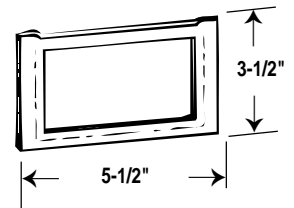

## CONTINUOUS CARD HOLDER

For 3" by full length card. For use on end panels or card holder panel. Furnished in black PVC. Available 3" high up to 32" long. Card holders fasten with double sided tape.

Unit No. - MPCCH14 (up to 14")  
MPCCH32 (14" thru 32")

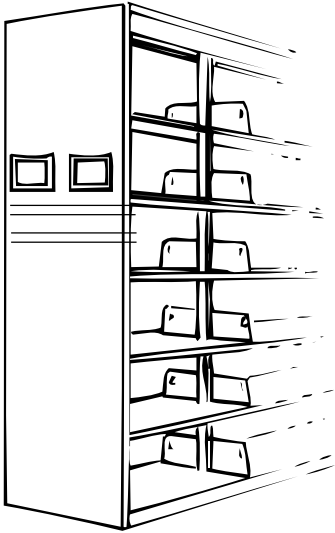
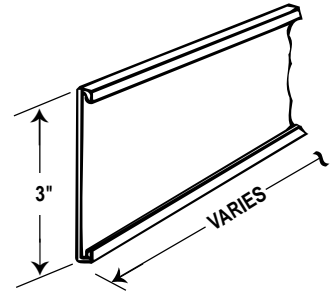

## RANGE FINDER

For use on end panels or uprights for identification of range components.

Constructed of 22 gauge painted steel.

Holds 3" x 5" cards. Clear plastic cover available.

Unit No. - 31140-015

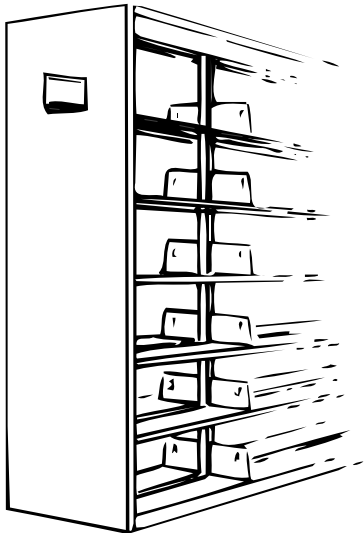
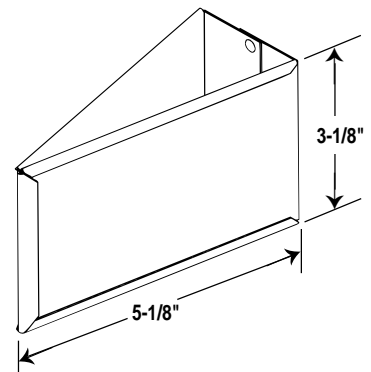

## SHELF LABEL HOLDER

Holds 5/8" x 5" card. Clear plastic, clip-on type.

Unit No. - 00944-040

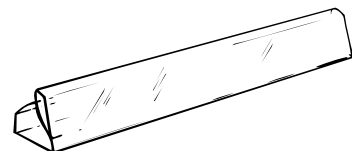
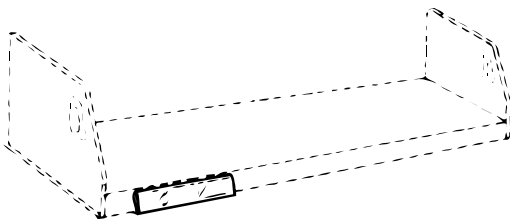

# CORNER FILLER

For Closed Base

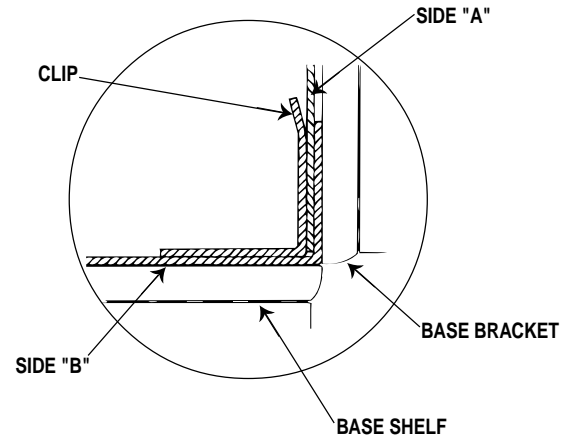
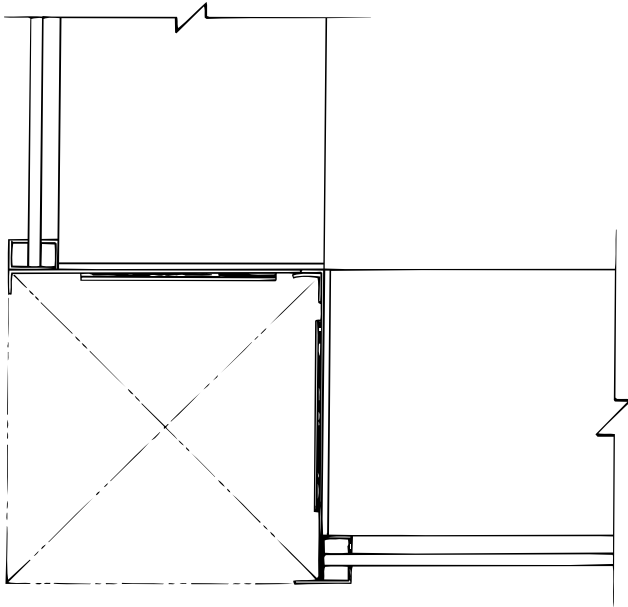

## FRONT CORNER CONNECTION



**SIDE "A"**



**SIDE "B"**

CORNER FILLER TOP

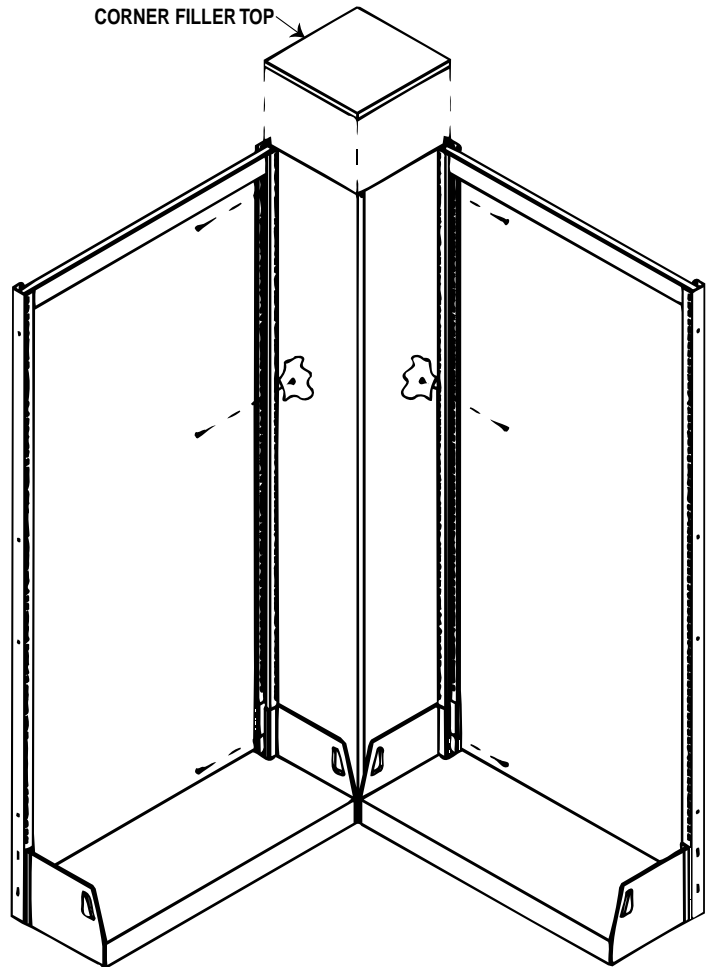

Material - 18 gauge steel.

### NOTES:

1. Add 2" to nominal depth of base shelves for hinged periodical shelves.
2. Standard corner fillers are available in heights and depths that correspond to nominal sizes of adjacent units. Custom sizes are available; contact factory.

# INTERMEDIATE WALL FILLER

For Closed Base

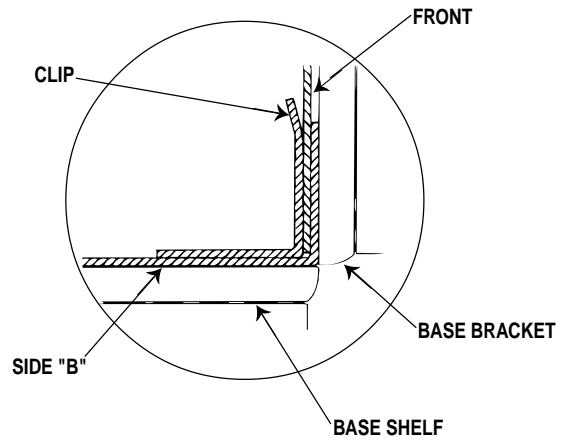
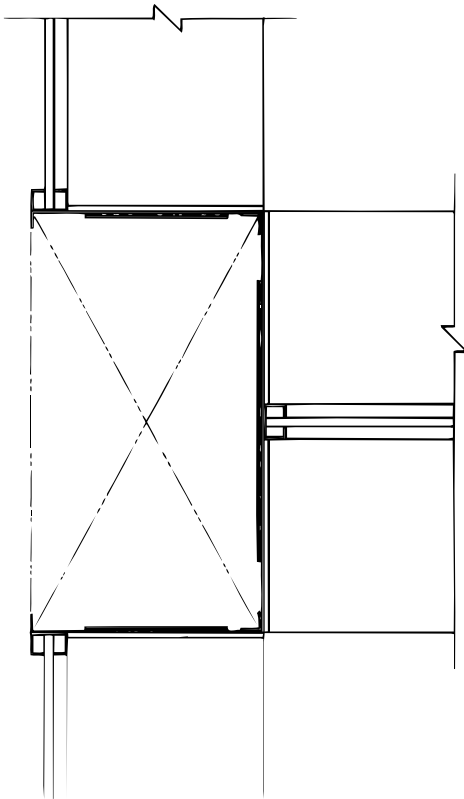

FRONT CORNER CONNECTION  
TYPICAL

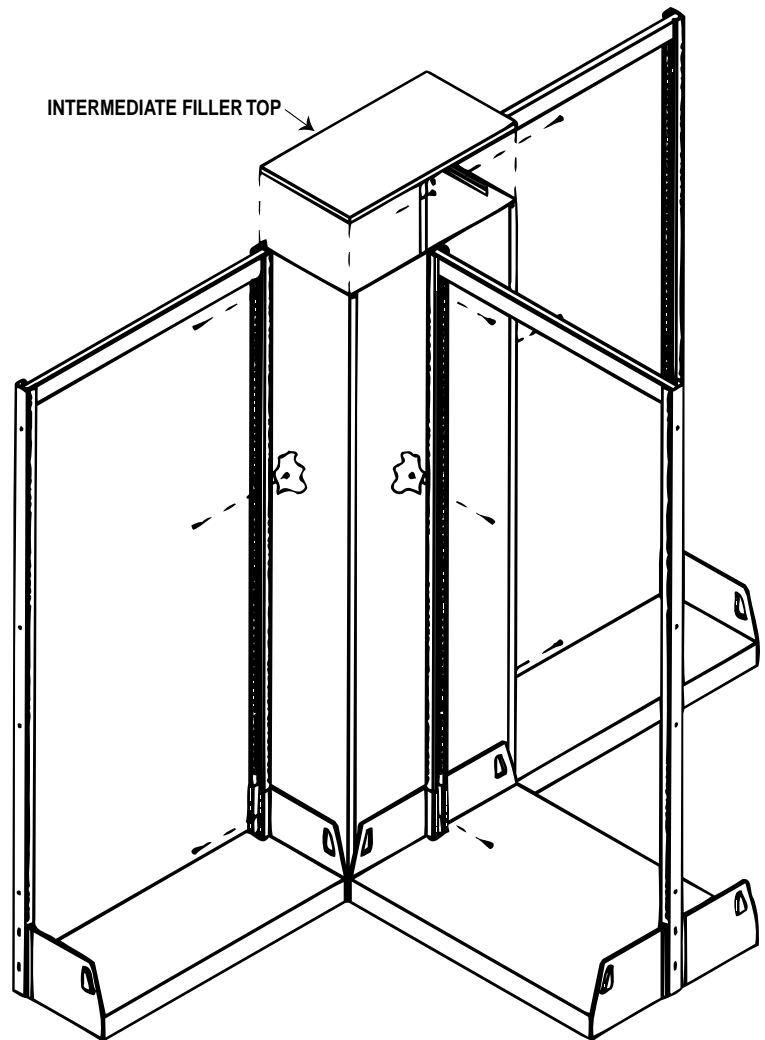
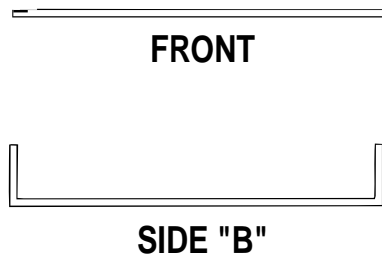

Material - 18 gauge steel.

## NOTES:

1. Add 2" to nominal depth of base shelves for hinged periodical shelves.
2. Standard intermediate fillers are available in heights and depths that correspond to nominal sizes of adjacent units. Custom sizes are available; contact factory.

# TRIANGULAR FILLER

For Closed Base or T-Bar Base

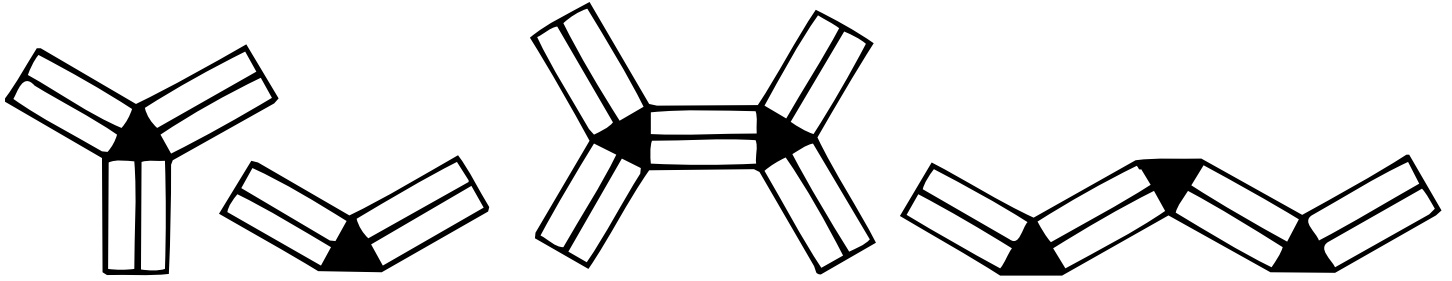

Y-SHAPES

V-SHAPES

STAR-SHAPES

ZIG ZAG FORMS

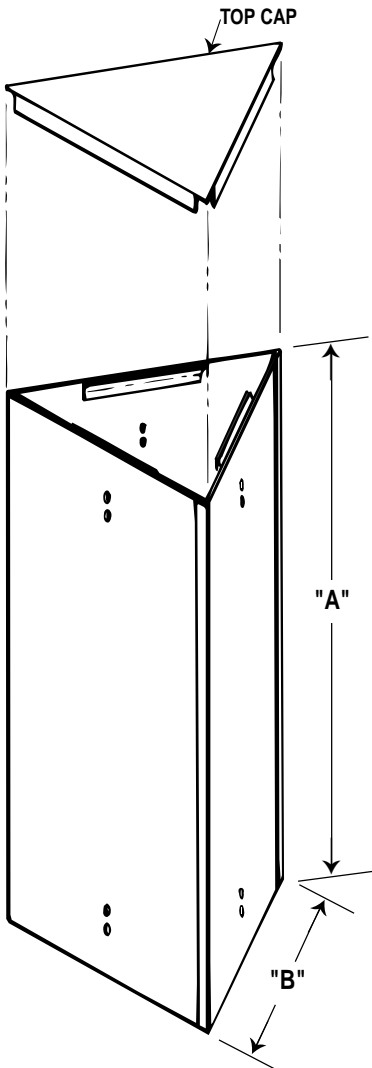

"A"	"B"
42"	16"
54"	18"
66"	20"
78"	24"
90"	-
93"	-

Material - 18 gauge steel

NOTES:

1. Add 2" to nominal depth of base shelves for hinged periodical shelves.
2. Standard triangular fillers are available in heights and depths that correspond to nominal sizes of adjacent units. Custom sizes are available; contact factory.

# T-BAR CORNER CONDITION

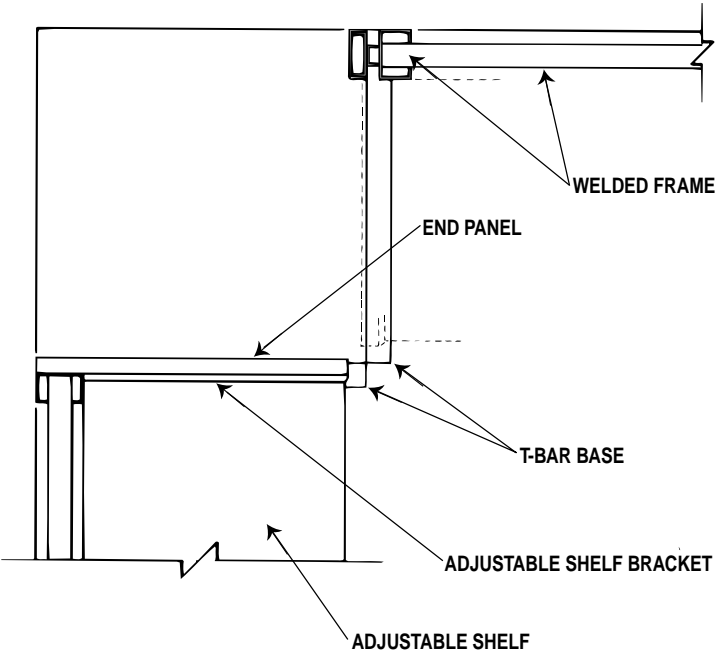
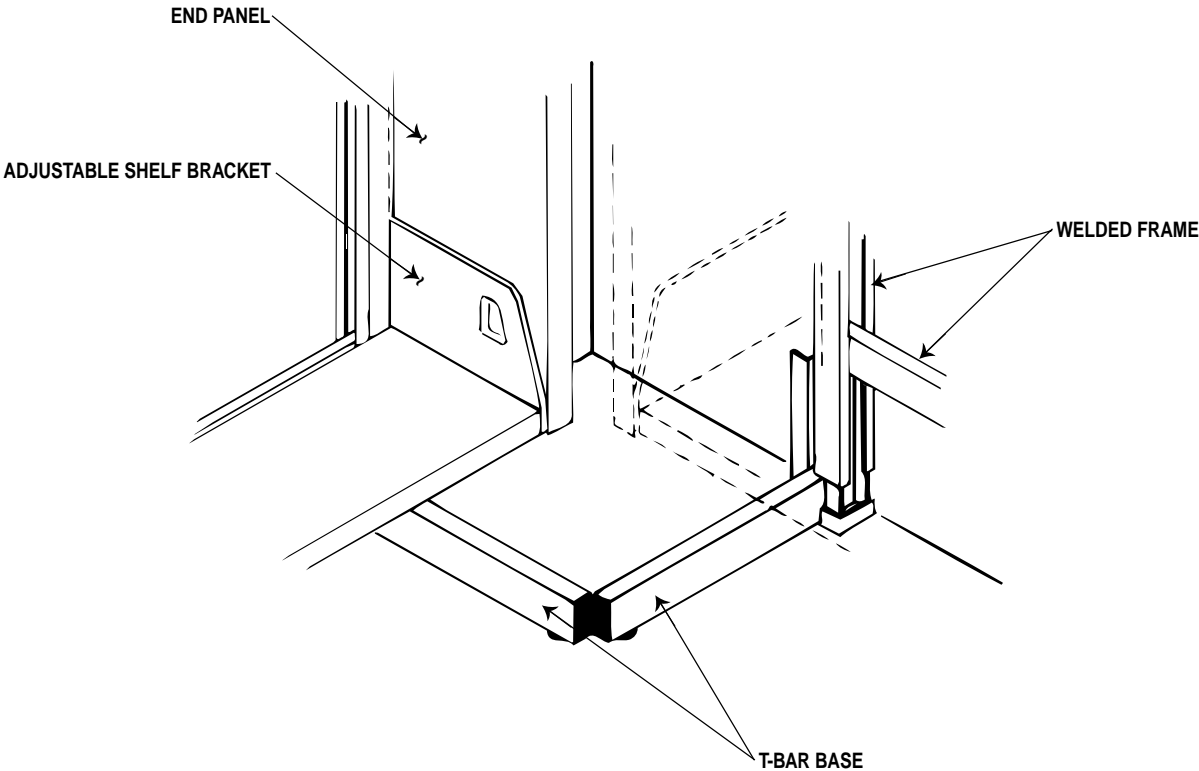

# CLOSED BACKS

For Closed & T-Bar Base Bookstacks

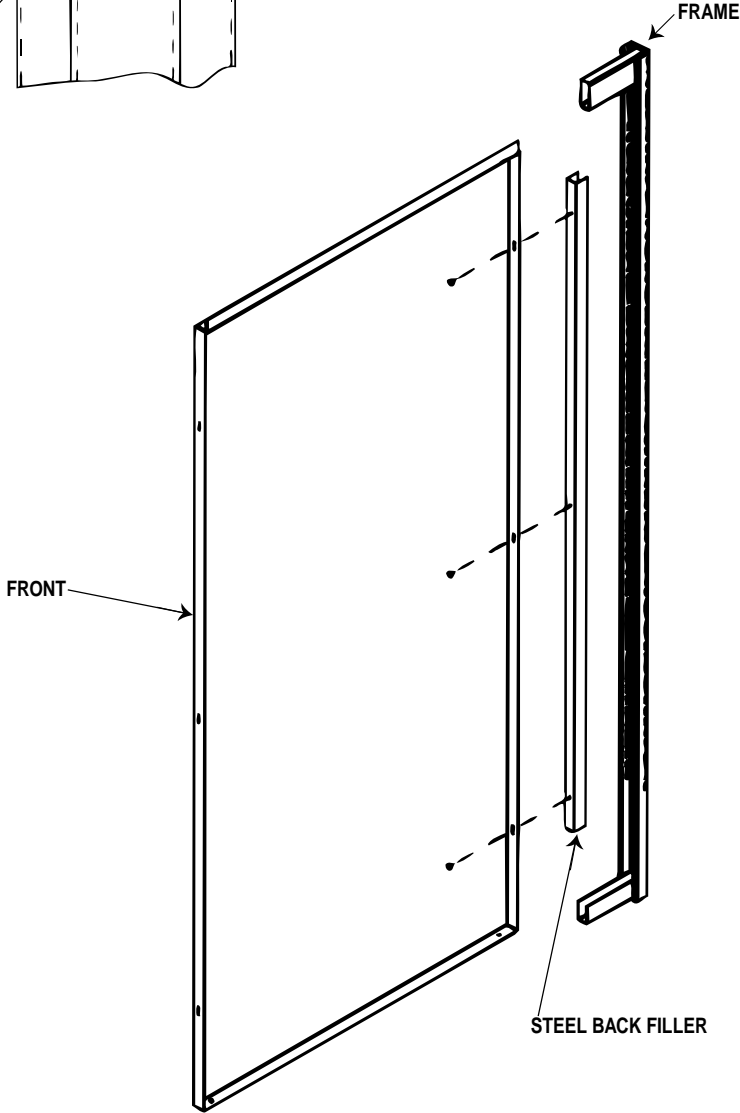
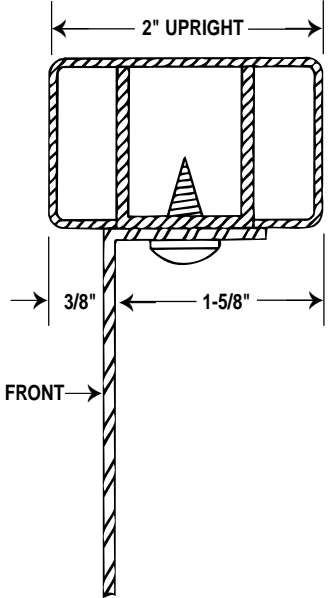
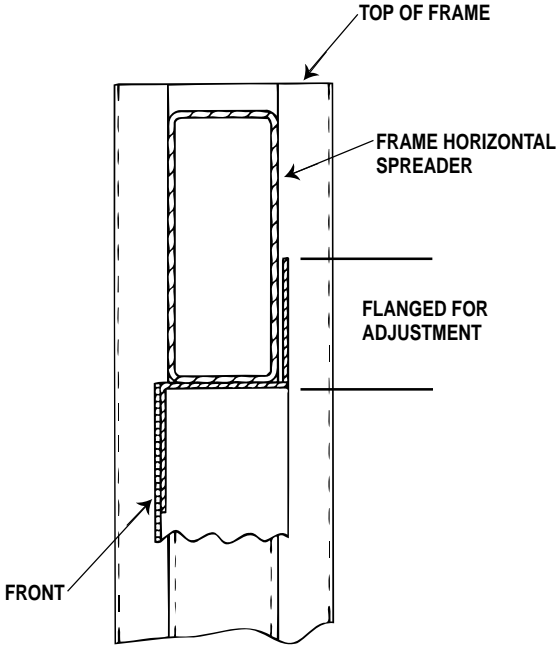

Fills void between uprights, top and bottom rails.  
Steel backs on single faced wall units may incur special solutions for anchoring those units. Contact factory for technical assistance.

# TRANSVERSE TIE STRUTS

## (Top Tie Struts)

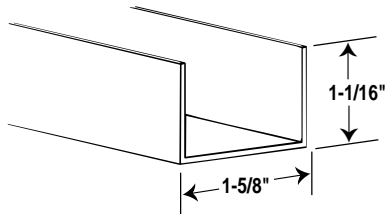
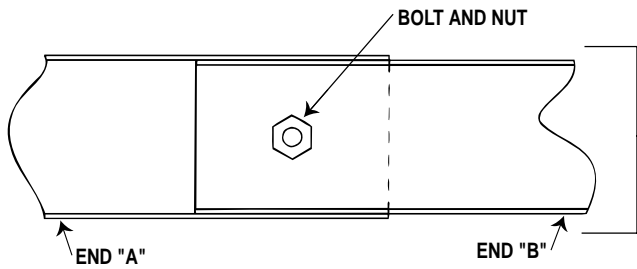

END "B"

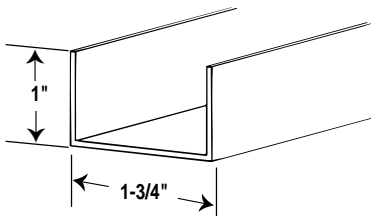

END "A"

Alternate method of securing ties to tops of welded frames.

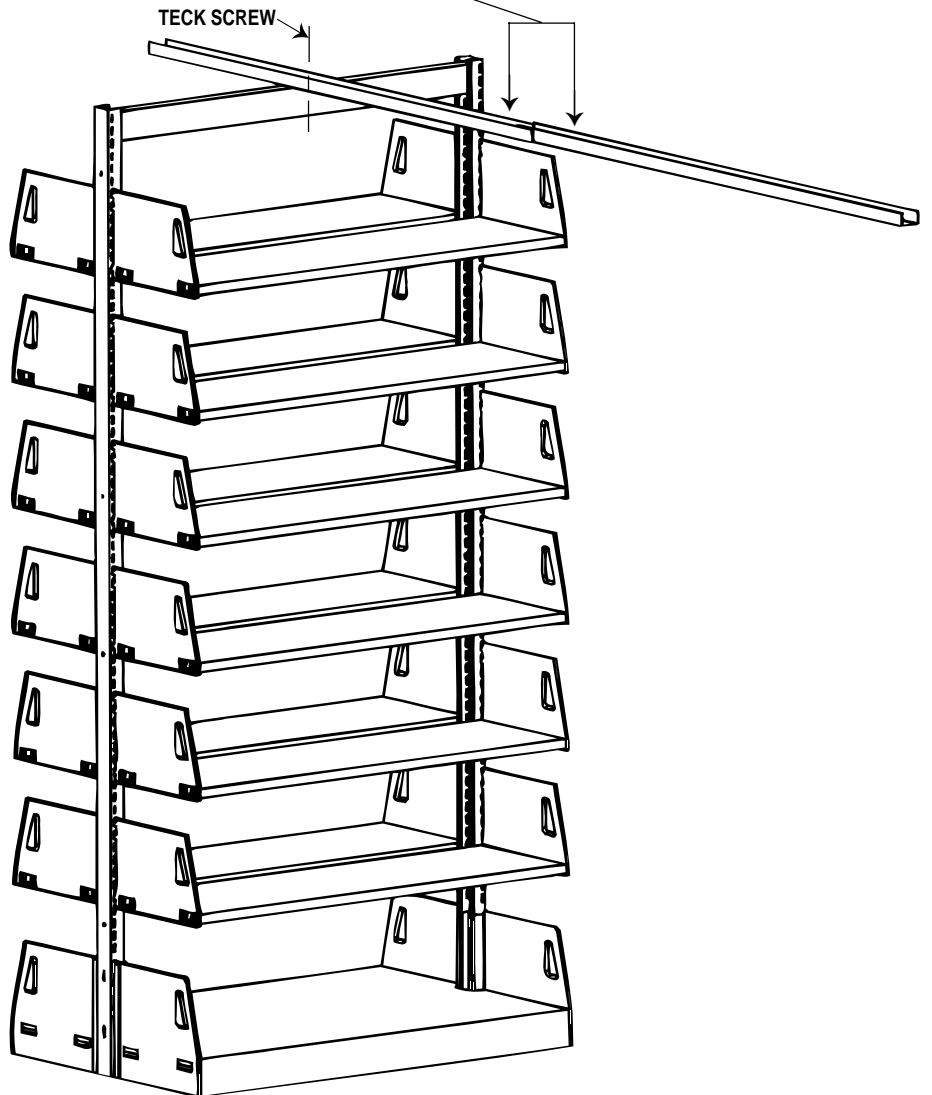
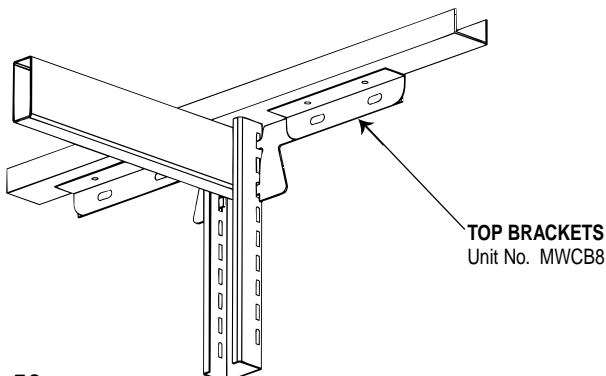

1. Top Tie Struts are required where a more rigidly secured system is required, where catalog numbers end in a number "2", and on units 78" or higher.
2. Top Tie Struts are attached to the top of units and transversed to wall-anchored units or building.
3. Top Tie Struts are 96" long and field cut to fit application.
4. Top Tie Struts may be used with floor anchors or without. Contact factory for technical assistance and placement.

# NEWSPAPER RACK

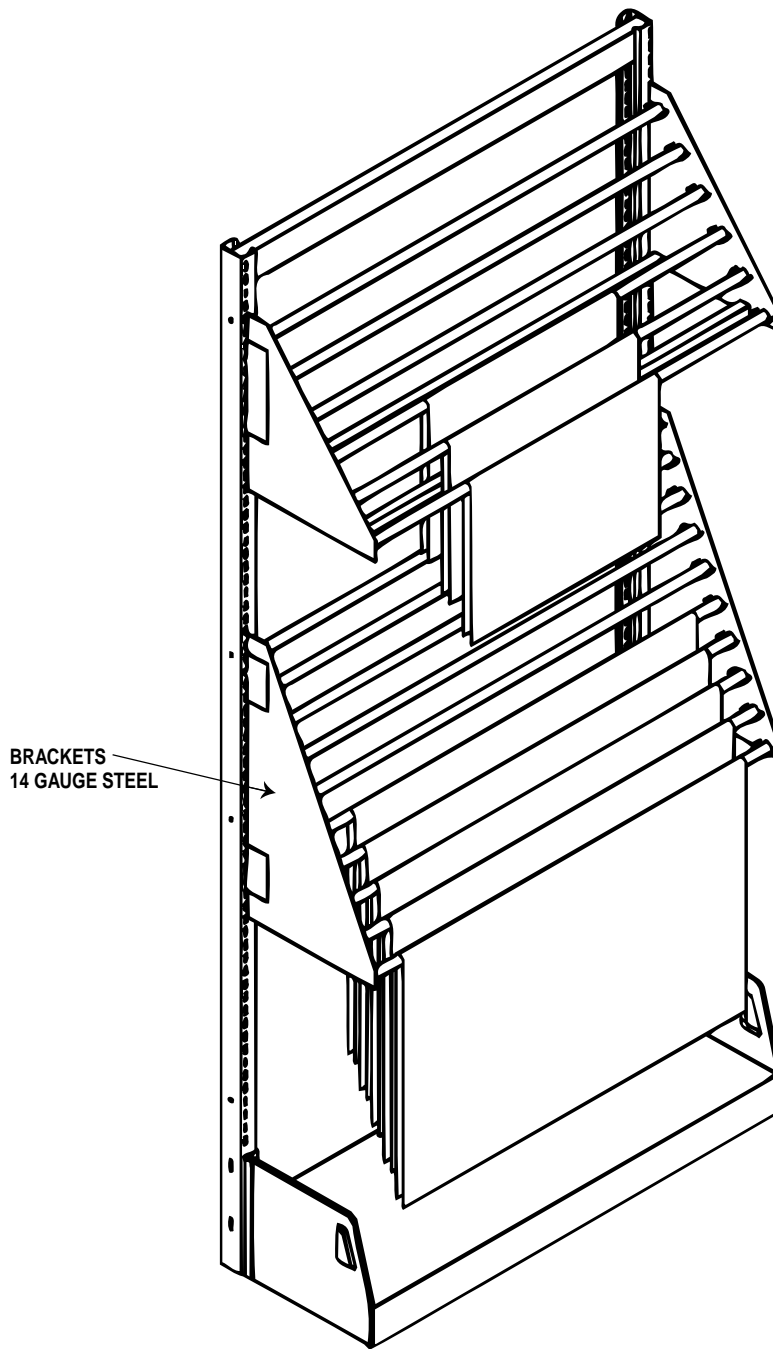

Available in 36" wide only.  
 Use with all frames and column strips. Frame, base shelf and sticks not included.

NOTE:  
 Newspaper sticks are available from bookstack manufacturer at additional cost.  
 Unit No. - 00946-020

Six Holders Unit No.	Ten Holders Unit No.
31600-025	31600-027

# MOBILE BOOK STACK

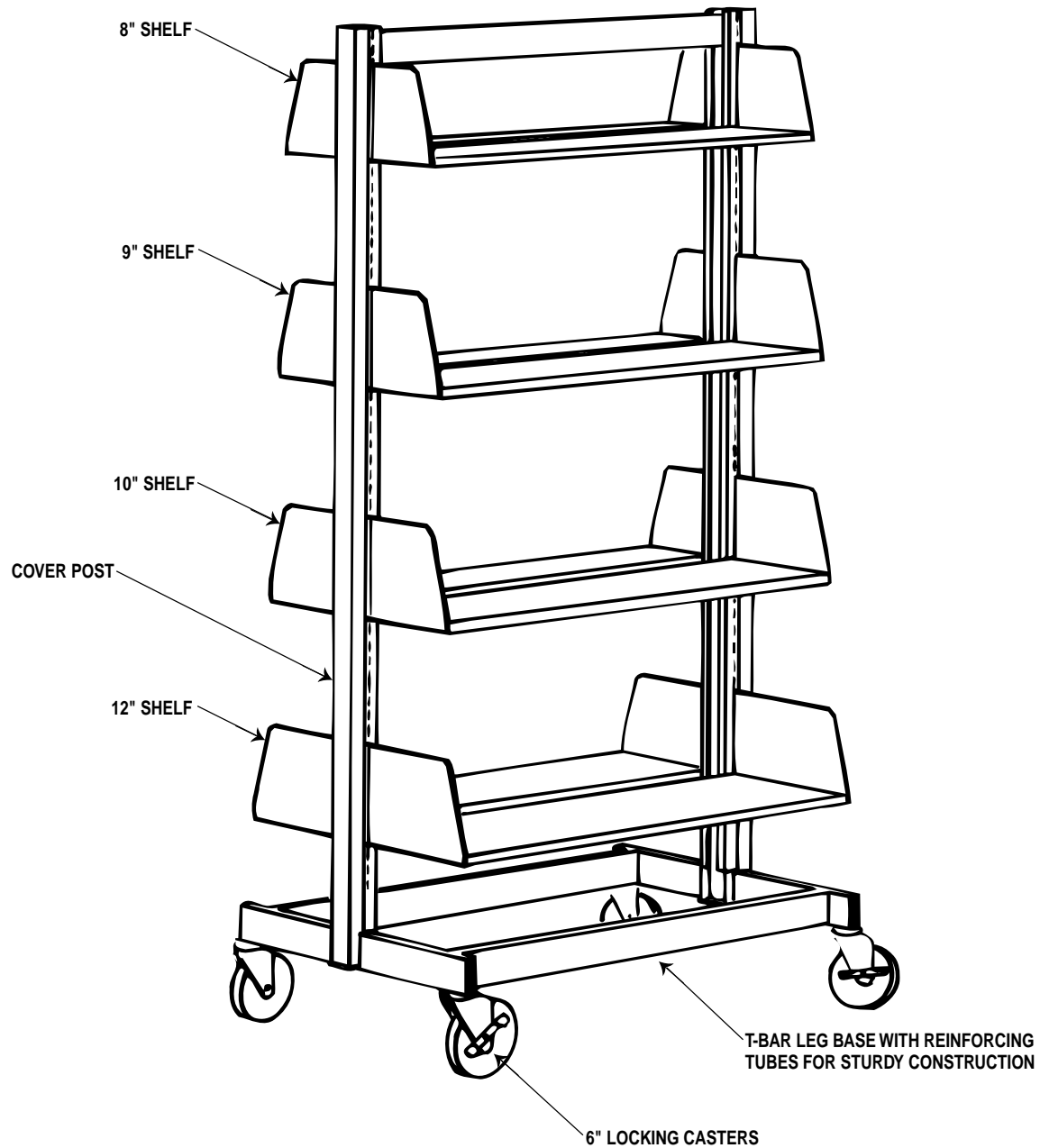

Recommended for frames 66" high or less. Available in double faced configuration only.

All styles and type of shelves can be used.

May be used as restacking cart or to create a moveable range. Range lengths not to exceed 2 units long.

# Notes

# Notes

# Notes

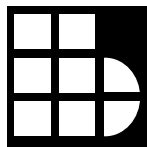

**Borroughs**

**C O R P O R A T I O N**

3002 N. BURDICK STREET ■ KALAMAZOO, MI 49004-3483  
800-748-0227 ■ FAX: 269-342-4161 ■ [www.borroughs.com](http://www.borroughs.com)