

EASY-TRAK™

MORE FILES...LESS SPACE

Responsive Drive System

- *Efficient, economical solution for handling your larger filing and storage needs.*
- *Accepts Record Master® and Rivet-Span® shelving from 24" to 60" deep, up to 15' long.*
- *Responsive carriage movement eliminates "lag" experienced with some current systems.*
- *Full Five-year Product Warranty.*

Easy-Trak's geared up to handle larger filing and storage tasks. Its Responsive Drive System – an undercarriage drive – handles heavier loads and longer carriages with Easy-Trak's proven quality and economy.

The Responsive Drive System or RDS allows Easy-Trak carriages from 24" to 60" deep and up to 15' long! RDS drives the carriage wheels directly via a continuous drive shaft, unlike Easy-Trak's Direct Drive System which drives the carriage via a large gear and drive track. Having the drive shaft connected to the front, middle and end wheels eliminates carriage lag time associated with longer carriages and assures smooth and responsive movement of the entire carriage. RDS aluminum unibody carriages use larger, extra-strength channels and angles with a 3 1/2" diameter (instead of Direct Drive's 2"), dual bearing, hardened steel wheels to carry RDS's larger and heavier loads. This provides the reliability you need.

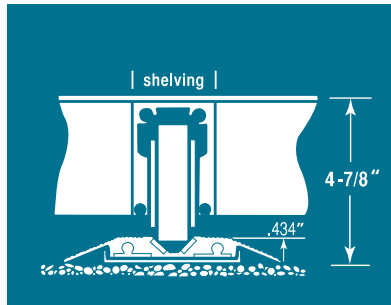

RDS's mechanical-assist chain and sprocket gearbox allows easy manual operation of the system. The gearbox's 16:1 ratio permits the longer carriages and their heavier loads to be moved with little effort, allowing quick access to any file or stored item. Plus, the one-spoke handle has a built-in carriage lock mechanism for safety.

Like all Easy-Trak Systems, RDS installs quickly and easily on carpet, tile, wood or concrete floors. Unlike many mobile installations which are permanent and expensive, RDS requires no special tools, no complicated alignments, costly platforms or expensive grouting. Our adjustable ADA compliant track can be leveled at any time, even long after installation and loading.

You can count on Borroughs Easy-Trak Systems to provide practical and economical solutions to filing and storage problems.

Anti-Tip Features

The RDS undercarriage drive system can be ordered with an optional anti-tip rail, which is attached to the floor with expansion fasteners. Anti-tip is recommended when the ratio of shelving height to carriage depth is greater than 4:1, and should always be used in seismic zones.

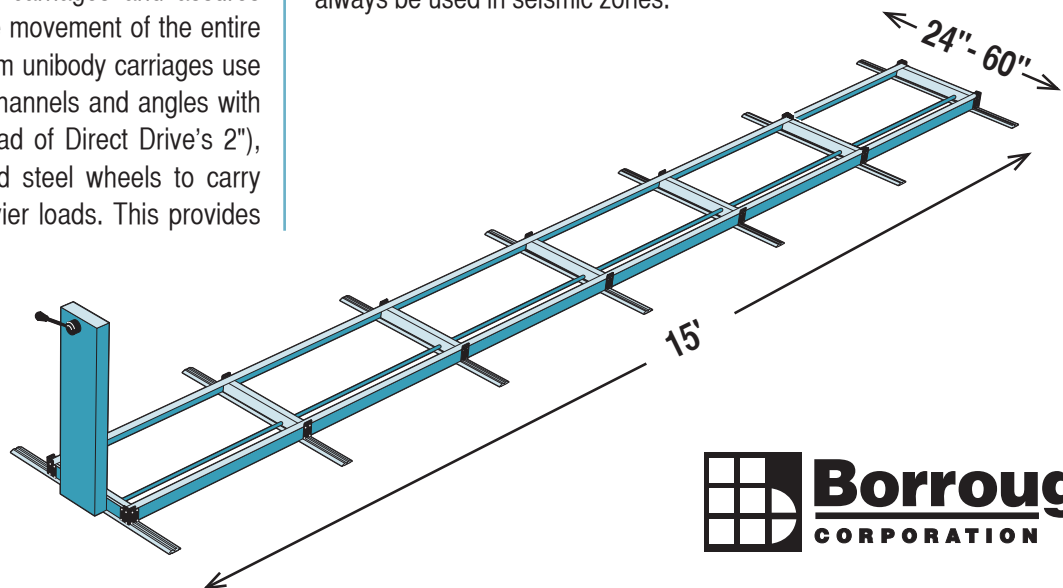

Why Easy-Trak™ Responsive Drive System works so well:

1. Versatility

Can be used with many Borroughs filing and storage units to increase storage capacity and make smart use of space.

2. Carriage

Durable, unibody, anodized aluminum.

3. Axle

Shaft connects to front/middle/end wheels for positive movement of the entire carriage, eliminating "lag time".

4. Adjustable Anti-Drift Track

Set screws at 3" intervals provide 1/4"-1/2" of vertical level adjustment.

5. Drive

Manually operated 16:1 ratio gear box and continuous driveshaft assures responsive, uniform movement.

6. Wheels

Hardened steel, 3 1/2" diameter, dual bearings; rated at 2500 lbs. per wheel.

7. Load Capacity

Up to 1000 lbs. per linear foot.

8. Track

ADA low-profile aluminum track requires no drive track or costly platforms.

9. Warranty

Full five-year Product Warranty on all systems and hardware.

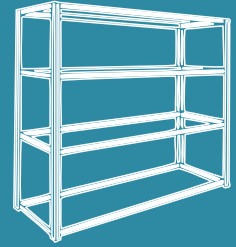
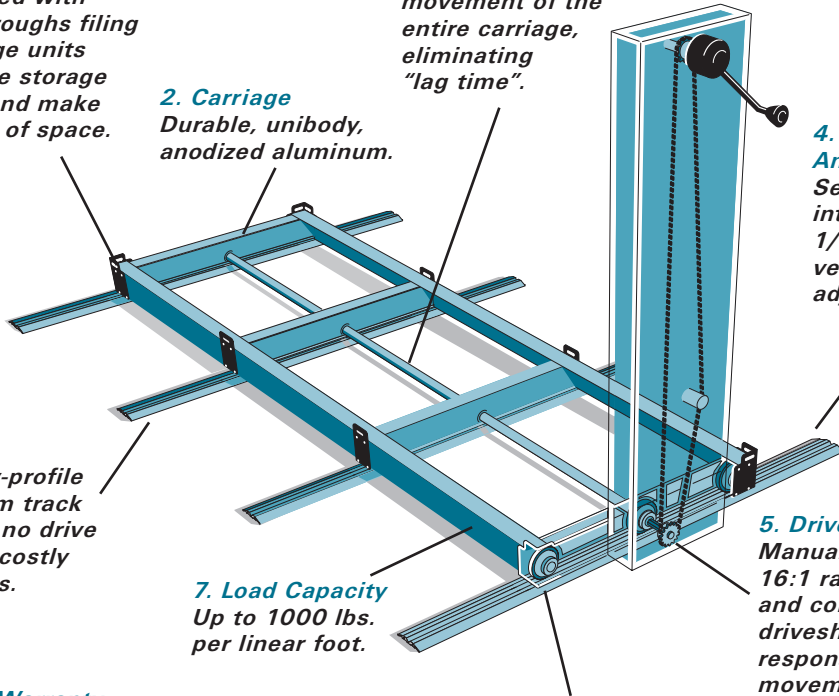

Rivet-Span®
Shelving

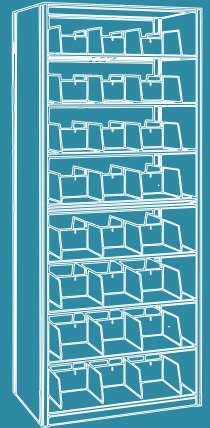

Record Master®
Shelving



Box Edge Plus®
Shelving

More files and storage in less space...

Turn this space (120 sq.ft.)

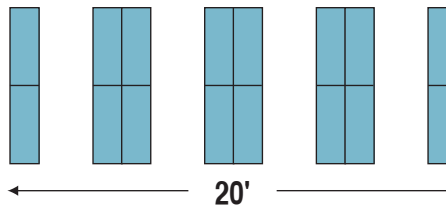

into this space (67 sq.ft.)

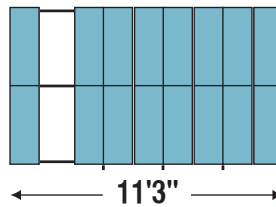

with an Easy-Trak Manual,
Direct Drive or Responsive
Drive Compacting System.

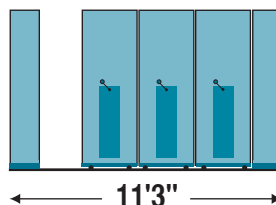

Borroughs
CORPORATION

3002 N. BURDICK STREET • KALAMAZOO, MI 49004-3483
PHONE: 800-748-0227 • FAX: 269-342-4161
www.borroughs.com

ISO 9001:2000 Registered
ISO 14001:2004 Registered